



# New Zealand POTTER

1974



NEW ZEALAND  
**potter**

**contents**

**SPRING 1974 VOLUME 16/2**

Driving Creek Potteries	2
Handbuilding	9
Chester Nealie	13
Small one-chambered kiln	14
Raku makers	18
4 generations of potters	22
Fassett Burnett and Batik	24
Exhibitions	28
Clay preparation	38
Electric kilns for stoneware firings	42
Howard Williams - ceramic decorator	46

NEW ZEALAND POTTER is a non-profit making magazine published twice annually

Subscription rates: Within New Zealand \$2 per annum, post free.  
Australia \$2.20. Canada and United States \$US3.50.  
Britain £1.50p. Other countries \$US3.50.

**editor: Margaret Harris**  
**administrator: Esme Marris**  
**cover and layout: Nigel Harris**

**advisors and helpers:**  
**John Stackhouse, Nigel Harris,**  
**Ruth Court (Auckland), Nola**  
**Barron (Christchurch), Audrey**  
**Brodie, Jim Brodie**

Cover: A railway at Driving Creek for moving man-sized pots.  
photo: Steve Rumsey

Editorial/subscription/advertising correspondence  
P.O. Box 12-162 Wellington North New Zealand Printed by Deslandes Ltd. Wellington



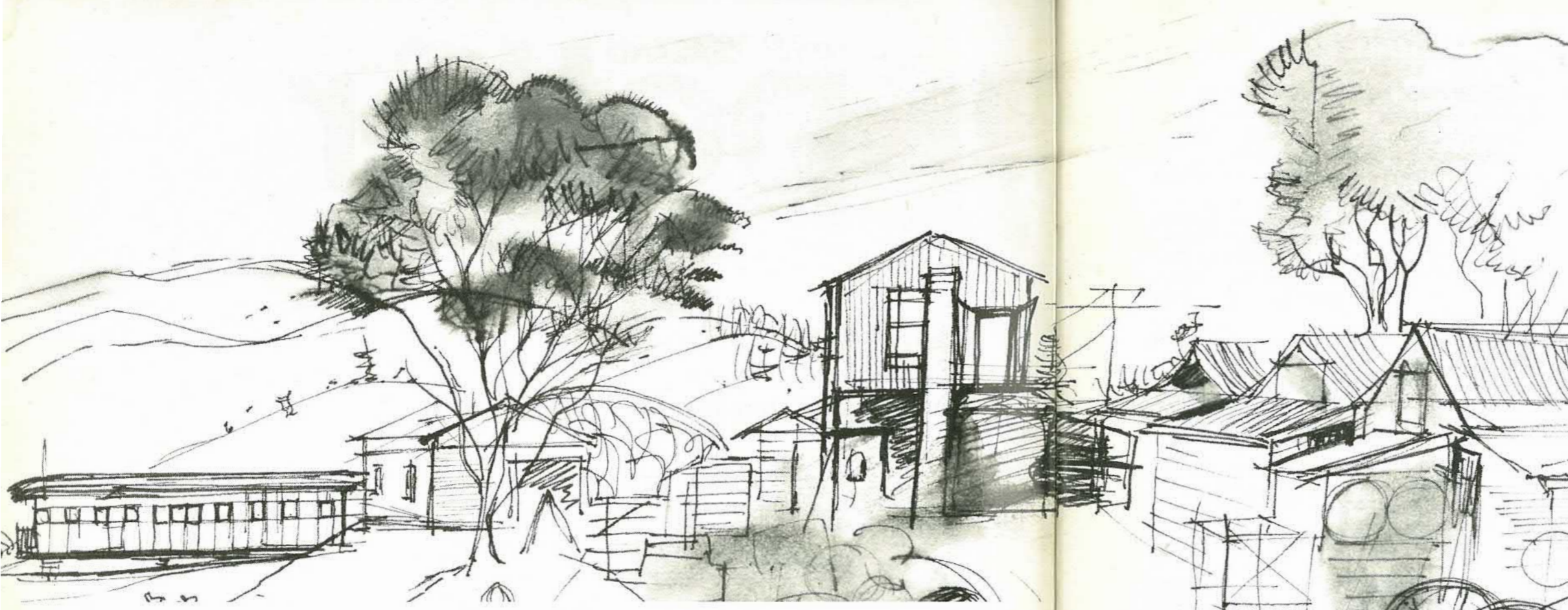

## Driving Creek Potteries - a way of life

The life of the potter is just as he makes it. Some like to create an appropriate environment before they start potting. Others pot first and gradually shape their environment as they go. Having just about done both now, I cannot say which is the best approach, except that this time it has been a communal rather than a personal endeavour.

My change of direction arose probably from the fact that potting for, to and by oneself is not so much fun as potting with others. The meaning and reality of pottery is basically communal.

One often wonders what is the nature of a bowl, jug or cup. Why are these things so important that we educated civilised beings are devoting our lives to making them when we could be using our talents to make ourselves more materially secure. So with various thoughts in mind, none too specific and none too sure, I thought it time to advance, pick up the swag and off once more.

There are eight of us at Driving Creek just now, with some comings and goings. It is important that the set up is elastic — in that whoever comes is no more bonded or bound than I myself would

wish to be. The aim is potting first and foremost. Good pots. Unless the emphasis is on producing work of the highest quality, the ship will sink.

So having acquired seventy carefully chosen acres we set to work. Now one year later, the end of stage one is in sight. At last it can rain and there is some sort of roof over most things that matter.

Like all journeys there have been the usual number of snags, pitfalls and problems by the way to be solved. Greatest of these in the physical sense is the plastic nature of the local countryside. In summer the clay is well behaved. In winter it turns quickly into slush. It moves, and can carry away walls and even buildings with it. We have laid mud concrete now and the far sighted souls who have helped make this place from the beginning are now assured of a comfortable place to live and pot.

The site was bulldozed out of a gently sloping south-facing hillside on which our buildings face towards the north and so create a sheltered sun-trap courtyard. With very little financial planning we had to put first things first and each move was considered with great care. In

retrospect one tends to bite off more than one can chew, but encouragement for our cause has made us press ahead more or less undaunted.

Believing in the principles of organic growth, I have tended to avoid set planning and allowed things to take their course. To take an example, our new workshop basically completed, has altered almost beyond recognition from earlier and more rigid concepts as to what a communal workshop would be like. It is good to let others who will be working there, shape their own environs, have their wedging tables, wheels and stillions where they will, and all the better if these things are constructed by their own hands. With the main frames of the workshop built on a massive post and beam principle, all partitions, walls, windows, floors are structurally independent of the main building allowing for alterations when necessary. Pot stillions are easily moveable and work spaces adjustable to suit the needs of each potter.

So far the potters themselves have largely built their own corners to suit their individual needs. They have shown a healthy degree of carpenterial skill. The "troops" have lately been weather-proofing the kiln shed which until now has been a wind funnel.

The scheme under which potters or students are accepted is also plastic and is designed to allow for as much human independence as possible. Complete beginners have set aside half

of every day for wheel practice. The rest of the working day is spent on work of a communal nature such as building or clay preparation jobs.

It is not right to set time limits on anyone for when they can start selling their pots, the time will vary with the outlook and the skilfulness of the student. During this period their food and lodging is provided. Other requirements are at their own expense. As these students begin to sell their work, they are given increasing time to pot, required to do less chores and begin to share in food costs.

A continuing, altering, but balanced system of give and take is thus allowed for, with of course complete freedom for staying or leaving. It is surprising how many foreign people, especially young Americans, are interested in this approach to making hand crafted pottery, and I get the impression that they favour this country after much globe trotting. It seems too that there is a spirited revival at hand for non-material values. Most of these young people are more interested in submerging themselves in their craft than making names or big money.

It is only by taking this approach that the pottery movement in New Zealand will retain any vitality. For me it is refreshing to see the "pots for people" philosophy replacing that of "pots for exhibitions".

Despite the philosophies and the ideals the fundamental practicalities of establishing a working pottery must hold first priority. The problems at times seem insurmountable. We face the usual series of bad firings. We lost two full wood fired kiln loads due to lack of vitrification of first the body, then the glaze. After a lot of testing some considerable rewards are in sight however.

We have found a local source of "Cornish stone" feldspar which mixed with our own white plastic clay yields a slightly translucent porcellanous stoneware body. We are fortunate in having abundant clays on hand ranging from white to yellow. However as with most northern types of plastic clays differential shrinkage is a great problem unless countered by suitable grogs and additives. It seems that the halyocite/kaolin ratio is high, causing the tendency for biscuit shrinking and embrittlement in the glost fired pot. For this reason it seems prudent to add certain aluminous fireclays and china clays or grogs depending on the plasticities required. Most of these very plastic local clays also contain much finely divided silica which could account for cracking during firing as well. They are certainly intensely refractory and gobble up at least two ounces of feldspar per pound of wet clay in order to secure vitrification alone.



In earlier years I used naturally feldspathic local clay containing rock-grog instead of much silica. While such a clay did not present so many problems, it was a rare deposit and we have just about exhausted it. The strongly plastic clays we are now using are by far the more abundant and are well worth researching on because of their ease of extraction and potential worth in stoneware bodies. While changing over to this type of clay during the past year or so I have had a few troubles due to lack of regular systematic research in assessing its nature and composition.

Our other great standby has been the terra cotta clays. This clay is ideal for bulky plant pots and outdoor sculptural pieces. This local yellow-brick clay is abundant and often very plastic. It tends to overlie the decomposed andesite on all moderate sloping ground both on ridges and in some valleys. It is a well weathered primary clay and is reliable when loaded with up to 60 per cent local stream sand. This sand consists mostly of water-worn andesite rock

particles, it hasn't excessive silica, and its freedom from calcium carbonate makes it an ideal opening grog. Biscuit cracking can still occur however if the sand content is not appropriate to the plasticity of the particular terra cotta clay being used.

It is no doubt surprising to the layman to learn how long it takes to sort out these clay problems, but the potter knows it is a lifetime's research, bristling with snags and promises of success, depending as much on insight and clear vision as on book knowledge.

In former years I had always been interested in digging and processing our own local clays together with designing and installing the necessary machinery. The new workshop here is laid out to include eventually all the machinery we need for blunging and pugging the clay bodies (parallel but different processes) and crushing of local rocks for grogs or glaze making. The blunger and pugmill are now operational. The pugmill is steam driven.

below: Brickell's wood fired kiln  
photos G.T. Radcliffe

Right: "Sometimes one wonders whether the place is a pottery, builder's scrap yard or a country engineering joint"

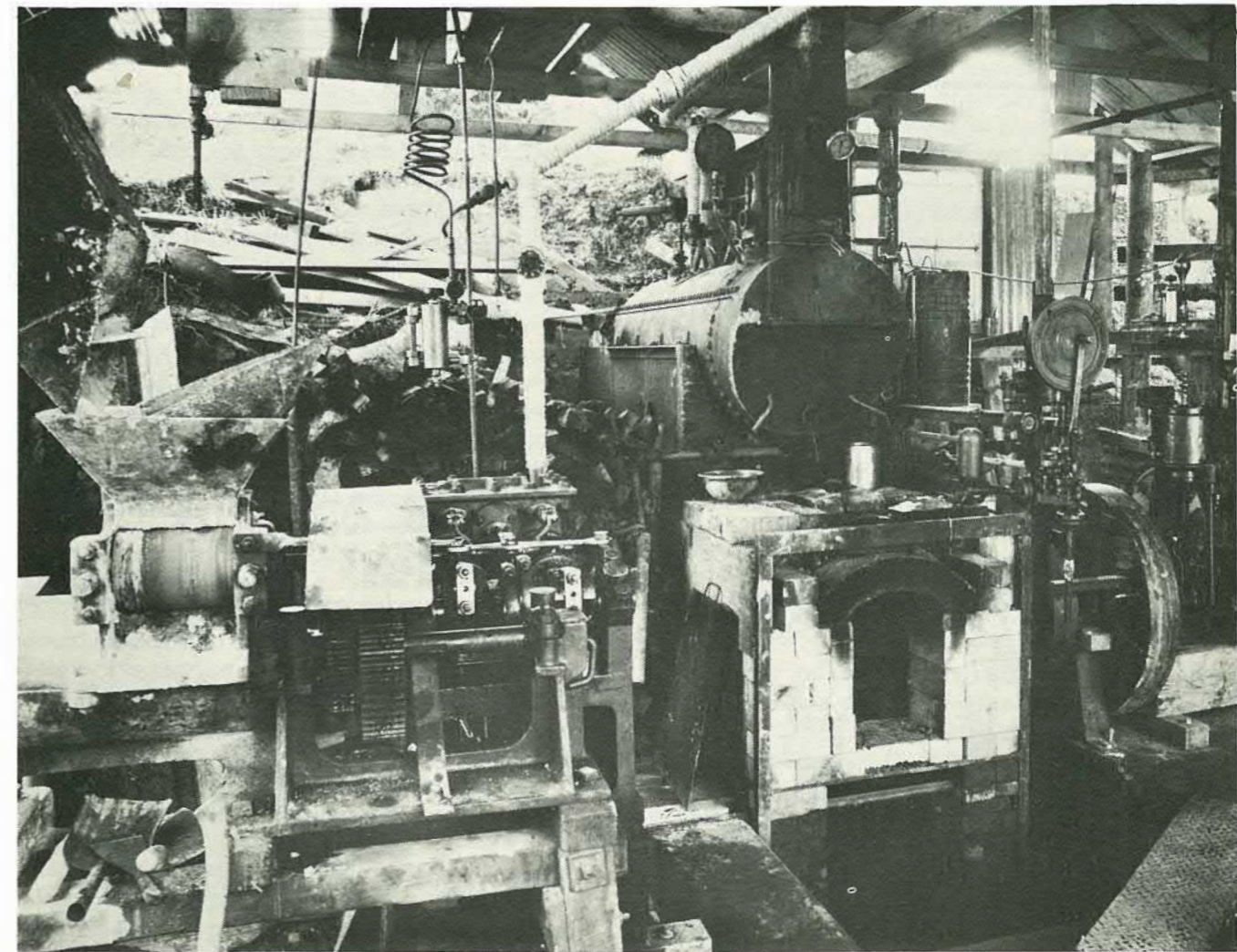
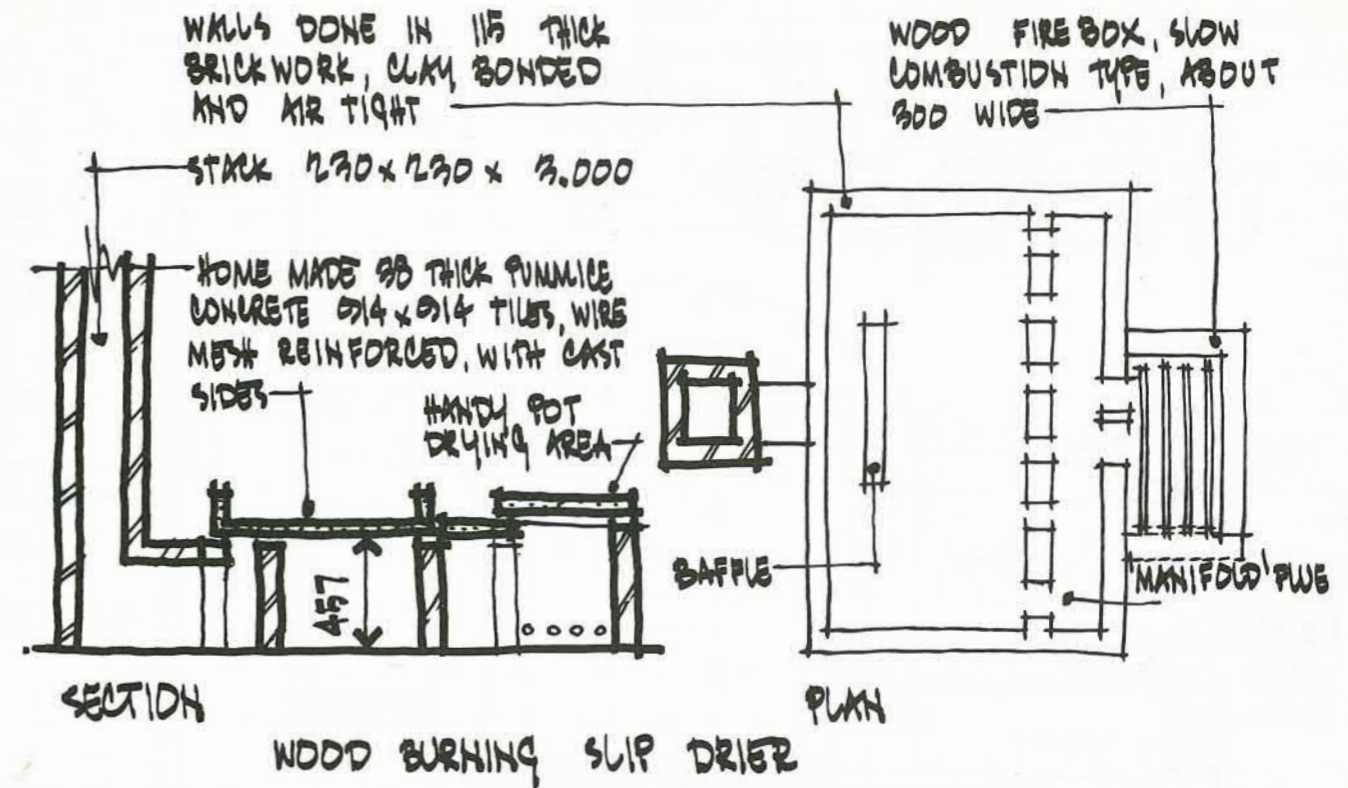



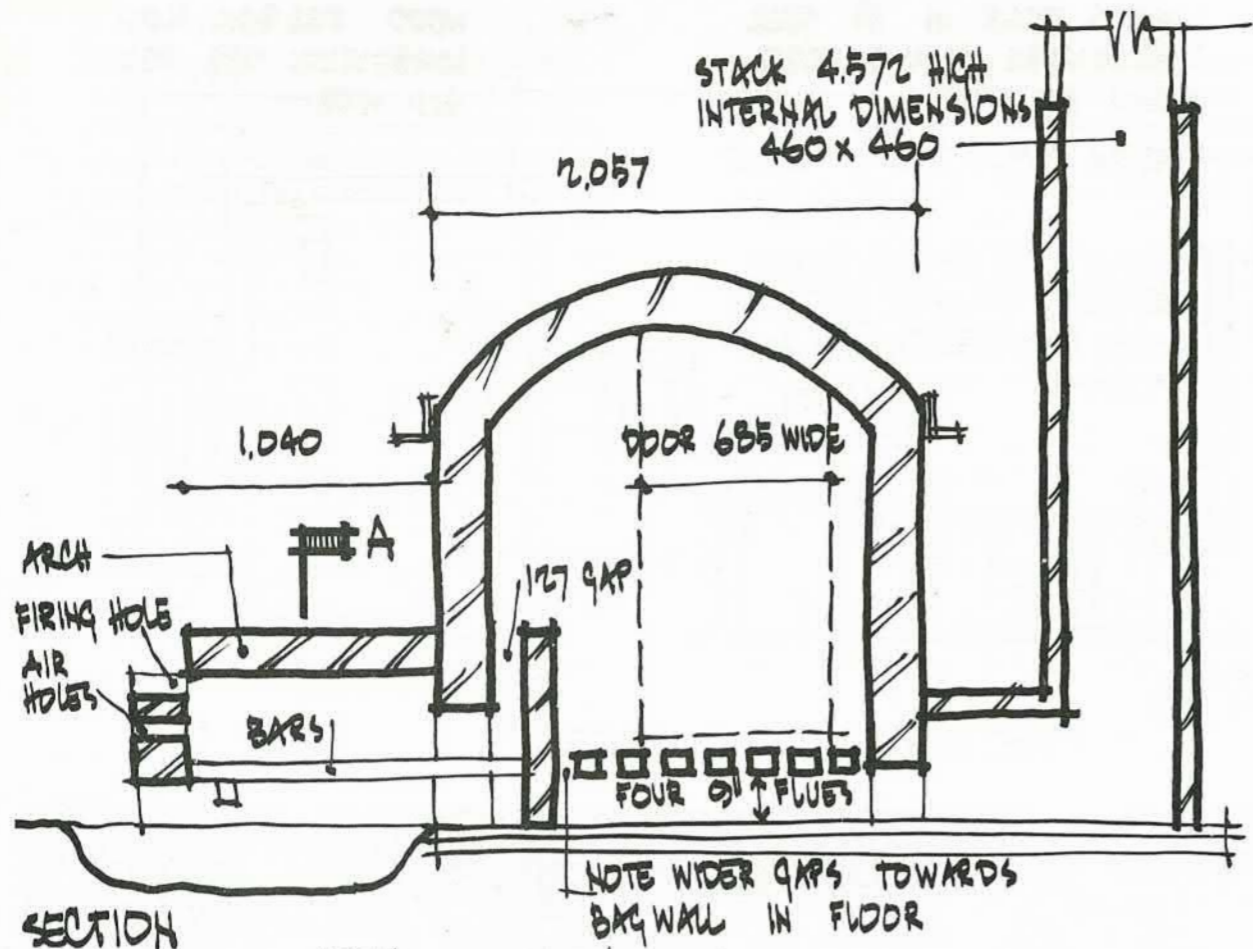

SECTION A

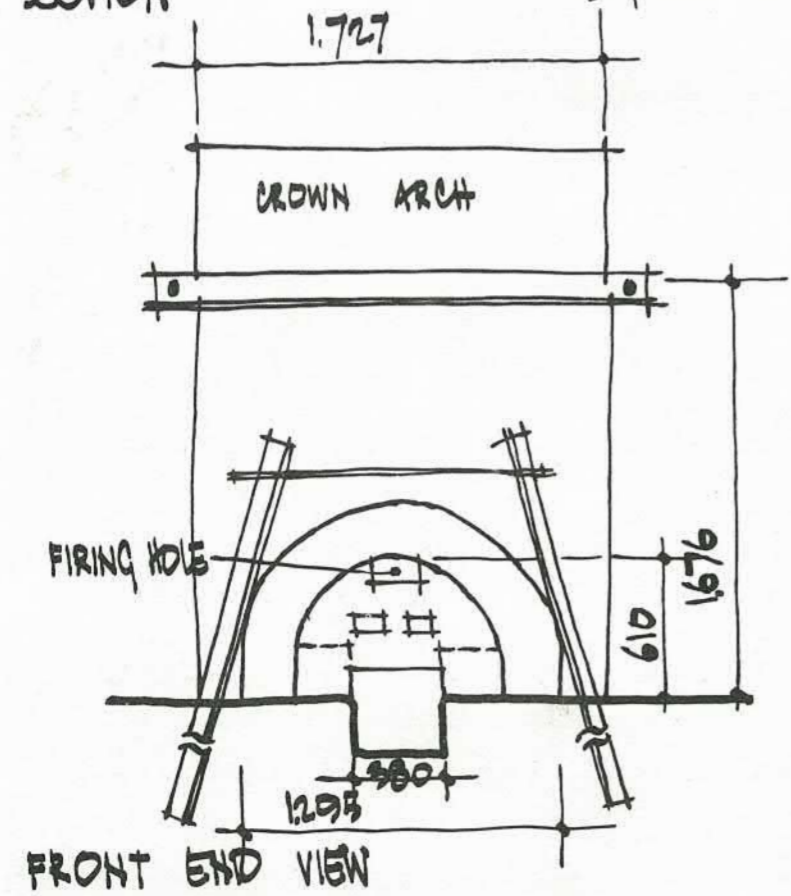

FRONT END VIEW

DRIVING CREEK WOOD  
FIRED STONE WARE  
KILN WITH DUTCH OVEN  
FIRE BOX FOR PINE  
SLABS

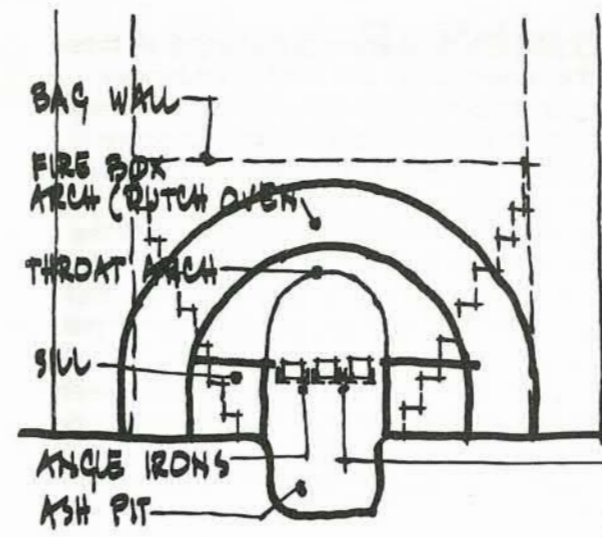

SECTION A

THROAT ARCH CONCENTRATES BURNING GAS FROM WOOD THRU THROAT, THEN SUDDENLY ALLOWS THEM TO EXPAND OUT IN A WIDE FAN AT RIGHT ANGLES, CAUSING MUCH TURBULENCE AND INTENSE HEAT GENERATION NB FIRE BOX ITSELF NEVER GETS MORE THAN A MILD RED HEAT, WHEN KILN IS AT CONE 10

METHOD OF BUILDING FIRE BARS - NOT MUCH AIR HAS TO COME THRU THE BARS, MOST THRU FRONT WALL LOOSELY BRICKED UP AND STROKE HOLE NB THE 'DUTCH OVEN' (USED IN STEAM POWERED SAW MILLS) IS ACTUALLY A GAS PRODUCER. SEEMS TO HAVE FAR MORE POWER THAN OIL OR COAL, GIVEN REASONABLY DRY WOOD

Our first machine was the blunger. It's an old four feet six inches diameter steel turntable obtained as scrap from a brickworks. On it is mounted a concrete farm paddock tank in which dips a stationary adjustable paddle. A half horse power electric motor provides sufficient power to rotate the tank slowly. The slip runs into a settling tank through a sieve and is later ladled on to a wood fired slip drier. When harvested for throwing, it is balled and placed into plastic bags. One of the students has taken over this activity and he keeps his wheel in the blunging shed so that he can maintain vigilance while getting in his throwing practice.

The pugmill is from the old Avondale College pottery classroom. I believe it was installed there by Bob Field who introduced Len Castle to stoneware pottery. It is of interest here that Bob Field was the first to introduce the Leach concept of pottery into our schools and literature. The pugmill was driven by a ten horse power three phase motor. As I did not wish to put in heavy wiring, the idea of steam power seemed appropriate and attractive. I, who have been a thorough devotee to steam since childhood, could now offer it a real job rather than making spare-time models.

I have the greatest admiration for the quiet and controllable power of steam: and there are other assets. Like the fun of the teamwork (stoker-engineer, pugmaster and clay passers), the soft sort of steam oil and the cheapness of the wood fuel.

A suitable water tube boiler was constructed and a small engine obtained from a scrap yard. After some vital repairs to the pugmill itself, the machinery was installed and has given

remarkable service for three years. Recently the equipment was dismantled, moved to its present site and reinstalled. It continues to give excellent service. We are using a slightly larger boiler which is intended to become a source of all power and heat requirements for the potteries in the years to come as the wood fuel is so cheap and abundant. Naturally a sauna bath house is becoming a top priority.

There seems an endless amount to be done and sometimes one wonders whether the place is a pottery workshop, builder's scrap yard or a country engineering joint.

I for one am more keen than ever to spend major time at potting. It's frustrating to be still involved with what seems endless building. Everyone here has finally obtained a chosen good spot for their wheels and we all feel that the pottery is just about to get under way. The two- or three-chambered trolley loading kiln will become a necessity as soon as the present two kilns become inadequate.

Although wood firing is a blessing, huge quantities of pine slabs are required. A stock pile has to be made and dried out for winter use. In summer the slabs can be used within a month of cutting. One of next summer's projects will be the storing of kiln wood, a task in which the troops turn out in full force. This again can be aided by mechanisation and some good potting time will need to go into constructing a railway and large wagons and drying shed to make wood handling easier.

Currently a local truck delivers bundles of waste mill slabs which we then cut to four foot firebox lengths with a chain saw. The wood is



then stacked near the kiln and covered. Wood for stoneware glost firing is stacked on a rack above the kiln's firebox to dry for later firings. The heavier pieces are stacked separately to be used in either the earlier stages in firing or for the boiler for steam raising. By using a railway system the wood needs to be handled once only and moved en masse to wherever it is wanted, by powerful human locomotives.

The wood-fired kiln is essentially an experimental model built in a great hurry last October to fire candle stocks up to terra cotta for New Vision's pre-Christmas exhibition. It was built largely from old white sandy chimney bricks from the local Star and Garter demolition, and was scarcely intended for firing up to cone 10. With such voracity did it go however, that we tried an experimental stoneware firing. This was successful so it received an A grade overhaul. It is interesting to find that when stoking correctly at full heat there is hardly a flame out of the stack but every pot right down to the floor on the coolest side is always perfectly fired and glazed. This is something of a revelation for such a crude kiln and shows up the effectiveness of the long hot flame from the wood.

Firing to full stoneware requires time and patience, and it is easier to choke the firebox and get an excessively long cool flame, than it is to stoke at the correct rate. A small bung near the top of the door is a handy tell-tale for the fireman.

On the subject of choice of wood, we find that dry thin pine is the ultimate fuel. At the lower stages of the firing cycle, tea tree is fine as it keeps in without so much attention. Any species of wood, wet or dry, is satisfactory for biscuit or terra cotta temperatures, but we keep to the thin pine for stoneware. The addition of dry seaweed to the fire at the end of a firing is fun as well as giving a toasted effect to the pots. It also provides an excuse for everyone to go off to the beaches and enjoy a swim while doing a rescue operation on sand-stuck vehicles.

Mention should be made of our satellite potteries — the old barn down in the paddock near the road. This building, centre of the potters' "Dos" now has a new wing with small drip feed stoneware kiln and a ground floor potting studio. Used mainly by one of the gang during the year it is thrown open for most of January for the Do, and provides shelter and a meeting place for all.

We hugely enjoy the free for all aspect of the Do, particularly the sight of the paddocks filled with tents of all shapes and sizes. The Do is to become an annual tradition. Every year we offer increasing facilities for making and firing the pots which seemed to get laid like so many eggs.

I should like to express gratitude to all those who have helped get our project underway. Although it has not been easy, I see it as a human necessity that potters get together to share thoughts and the tasks connected with the communal approach to potting.

On reflection this has been the basis of the world's traditional, and now timeless, people's pots of the past. So there is every reason that such an approach will be relevant also for the future.

I see the need for steering a course between the inanimate, mass-produced utilitarian pot on the one hand, and the one-off, individual, capitalistic style-bound aesthetic kind on the other.

*Apart from during the Do we cannot open the workshop to casual visitors during the year. It is very difficult to stop work and cope, and awkward for the students. It is easier if previous arrangements are made. Anyone wishing to buy our pots will find them for sale in the local craft shop in Coromandel where we intend to stock a good range.*

Thanks Barry

## About the potter's Do, 1975

As before, the Do proper can start on 7 January. However this year arrangements will be made to leave the paddocks open for the whole of the month, as several potters preferred to stay on and inspect our local scenery.

A possible feature of this occasion could well be the firing of the wood-burning kiln up to full stoneware. Again we will have terra cotta clay available in bulk and plenty of wood for those who simply must make pots.

Unfortunately the good ship *Presto* will still be out of the water as we have not had time to work on her this year. But we will try to arrange the islands picnic day using other means of transport.

We are gradually improving camping facilities and will have a wood fired hot water machine in the barn. You need your own toilet requirements and your usual camping gear. With a shopping centre only a mile away there are no food problems except an occasional shortage of good wholemeal bread. It is of course vital that we conduct another hangi and the stones from last time are being carefully guarded.

The Do is open to all potters of serious intent, whether full or part-time or beginners and their families. There is no charge. I have only one real problem — a bad memory for faces and names. So please forgive me if I put my foot in it.

## Hand Building

Every now and again we participate at a pottery school where the personality of the instructor is so sympathetic and the enjoyment she finds in her work so infectious that we are kindled with new enthusiasm for our craft. Such a school was the one recently given by Hiroe Swen, a charming Japanese from Australia, living and working at Canberra. There she and her husband, a graphic artist, have a private gallery where most of her work is displayed.

Her pots are mainly hand-made, and her schools in New Zealand were all on different aspects of this method.

Many of her ideas were new and exciting to us. They encouraged us to explore some more unusual approaches, and Hiroe Swen explained to us the various techniques she uses in her work.

She began by suggesting that we all made a small pinched pot. We joined two of these bowls together to make a whole and then we were instructed on her methods of decoration: the design was scratched on lightly and then tiny rolls of clay were closely pressed into the pattern to make a compact and flowing design.

These were fascinating to do — a time-consuming but peaceful occupation. Maori rafter patterns for instance could be adapted beautifully to this method.

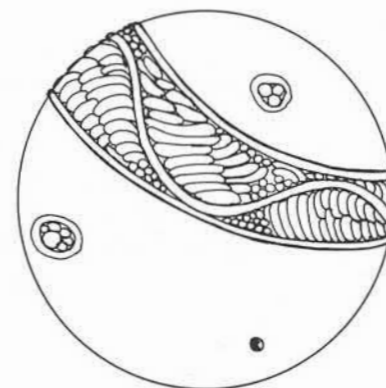

The next exercise consisted in making another small pot. Two slabs of clay were cut out and carefully joined by a roll of clay. We gently blew into the formed pot which we then decorated as we wished. It was a lesson in itself to watch Hiroe work with such care, love and patience.

On the second day we made use of the slabs of clay (prepared the day before). These were by then very stiff and would stand without bending. She cut them by using two sticks and a wire held taut in

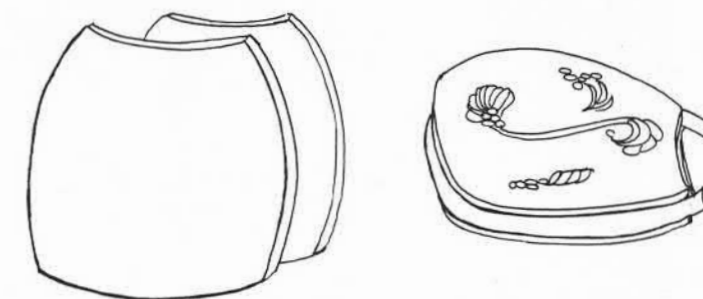

their notches (But no rolling, please!) The slab pot was carefully joined with slip without scratching. The slabs were quite thin and the openings were thickened with a coil.

It was interesting to see how Hiroe joined the two slabs:

They were not mitred, but joined flat, and after pressing them together an incision was made down the outside of the join and a small roll was laid on and smoothed flat. The usual coil was also put on the inside as well.

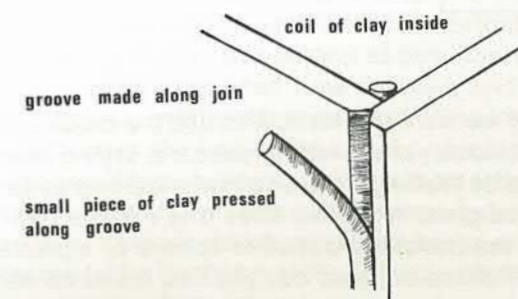
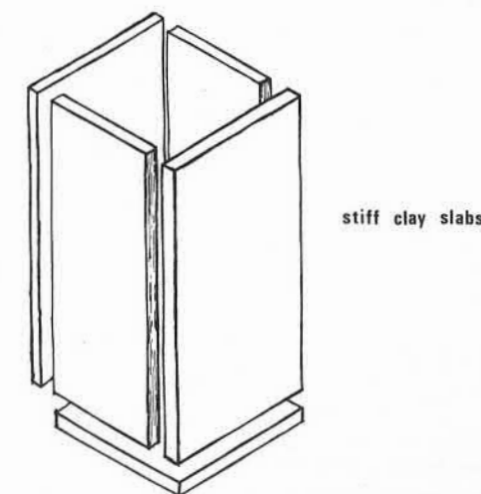



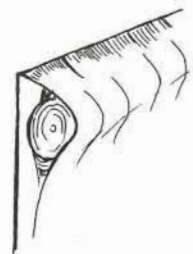

inside of pot at top

coil of clay at top of pot to give impression of solidarity

On these slab pots we were shown four different types of decoration:

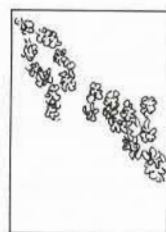

Little curved scraps, e.g. in the form of tiny petals, were shaved from the clay, and these little motifs were placed on the pot.



A soft slip was patted on with a putty knife and flattened.

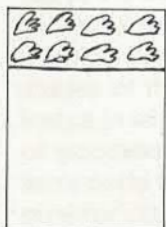

The same method was used, only with more substantial pieces of clay pressed flat. The pattern was outlined.

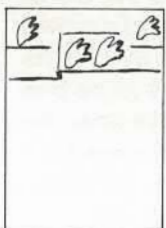

These motifs were also used to represent miniature trees on an incised landscape.

Later we were shown how to use the moulds we had previously made with great care, drying them in spite of Wellington's Southerly lashing at us. This was great fun. How does one make a ball within the hollowed-out semi-sphere of a plaster mould? Hiroe enjoyed our puzzled looks as we began to fill the mould with the textured pieces of clay. These were backed with a thin covering of

clay. Our semi-sphere finished, we were told to take a lump of clay and press it down, gently lifting the pot in the mould and moving it up and around by about thirty degrees. We proceeded to fill in the area in the mould which had in this way become empty and repeated this process until, at last, we had made a complete ball vase, a technique which we thoroughly enjoyed.

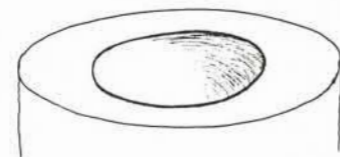

semi-sphere plaster mould



pot half made then turned in mould

The other mould we had made was a hump mould which was used to make a platter. First we had to draw a design.

From this we made the clay platter on the mould, starting it with small balls and strips of clay. Then the whole was carefully covered with small, even pieces of clay or completely with a flat slab. When this had been moulded flat, the whole was smoothed off and left to stiffen. The result was a clearly impressed design on the face of the platter.

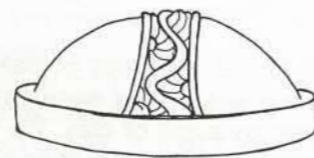

design placed on hump mould

Hiroe showed us slides — her large square platters were coiled, she explained. Straight away



Flora Christeller, Patti Meads and Evelyn Kelly attend the school in Wellington. photos: Evening Post.

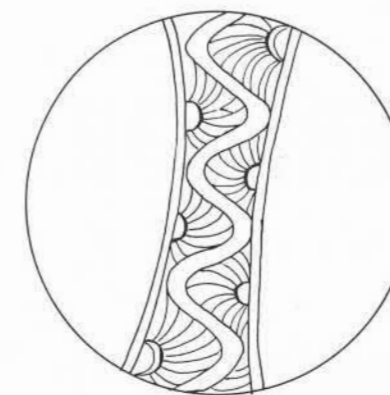

decorated interior of bowl

she proceeded to show us how she made them: She rolled short, sturdy coils between her hands. We tried this and found it rather tricky. Our coils danced all over the place, breaking and dropping on the floor. We watched her careful twisting and rolling the clay and then fixing it on the inside of her pot and pulling it into the required position.

In this and other demonstrations of her methods our most important impression was that of love, care and attention Hiroe gave to all her work. Nothing was missed, she took no shortcuts, and everything had to be as perfect as possible. All the time we were reminded how carefully and accurately a craftsman must work. She knew exactly what she was doing and the resulting pots were beautifully controlled. Hiroe is an artist, and combined with her enthusiasm went a delightful sense of humour which endeared her to all of us. She made the four days at the School into a happy, as well as an instructive time.

Flora Christeller



The demand for "LEACH" kick wheels is as strong as ever.

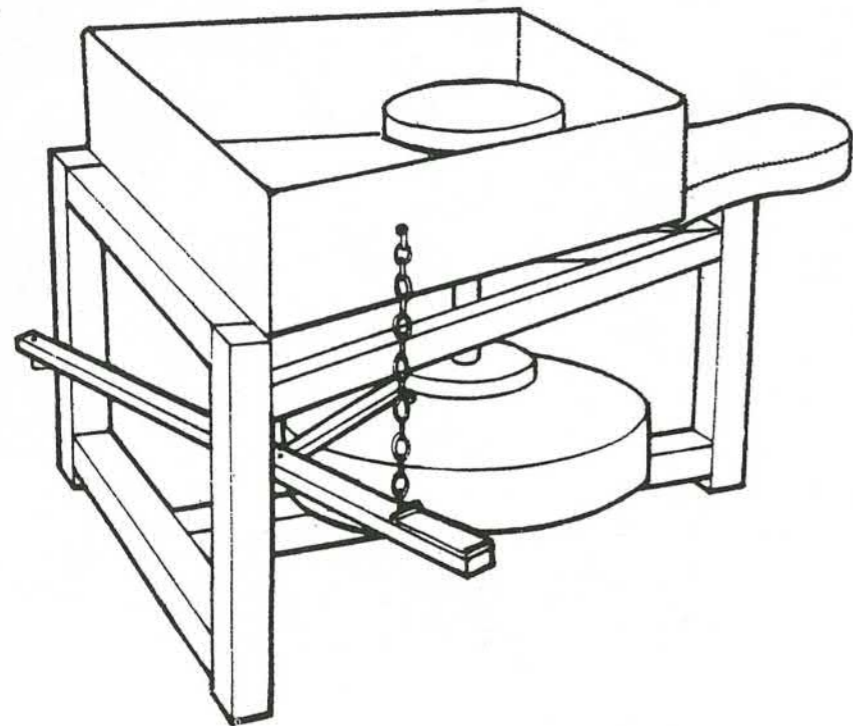

Kick Wheels :: Power Wheels :: Banding Wheels

## SEABOARD JOINERY LTD

"Authorised Manufacturers of LEACH Potters' Wheels"

Phones  
594-264  
599-571

151 Marua Road  
P.O. Box 11-035  
Eilerslie  
Auckland 5.

## Chester Nealie

"My pottery is influenced by my environment, hence my involvement in organic forms. I have a great love for the artistry of the early Maori. These are the forces influencing my work. It's important to me that my pots are exciting in a visual and a tactile way. Touch to me is the most important sense. I work in brown and white stoneware using oxides and natural glazes fired in a self designed twin chambered 50 cubic foot spring arch oil fired kiln".

Chester Nealie — self taught potter. At Auckland Secondary Teachers College he had the opportunity to handle clay. He was introduced to the Auckland Studio Potters and soon became deeply involved in potting.

Retired from science teaching 1972 to become part-time lecturer in pottery at North Shore Teachers College and to spend the rest of the time developing his own work.

Exhibited with the Auckland Studio Potters and the New Zealand Society of Potters. In April he exhibited in Wellington at the Media Gallery, Karori.

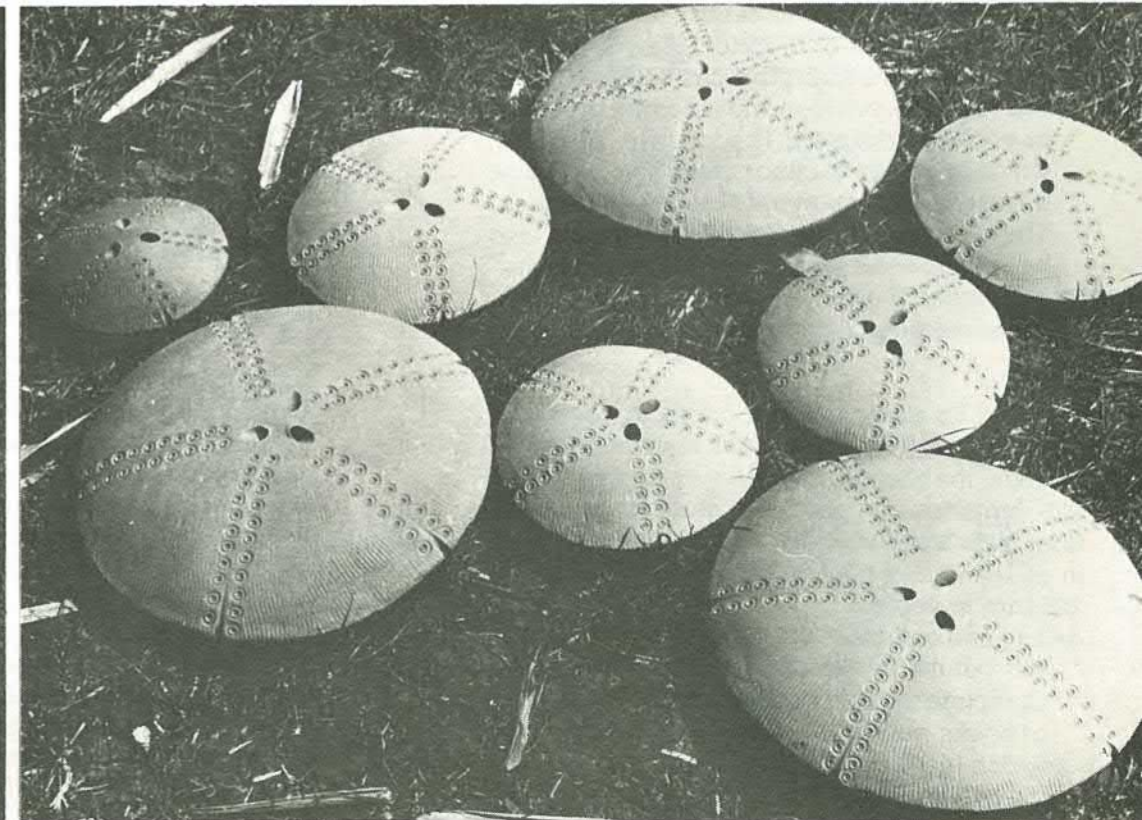
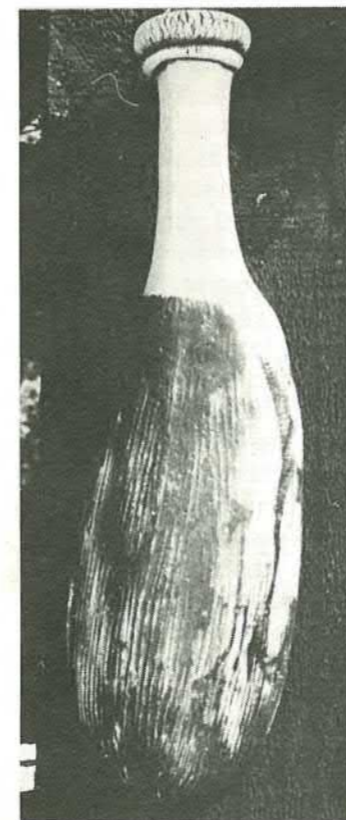
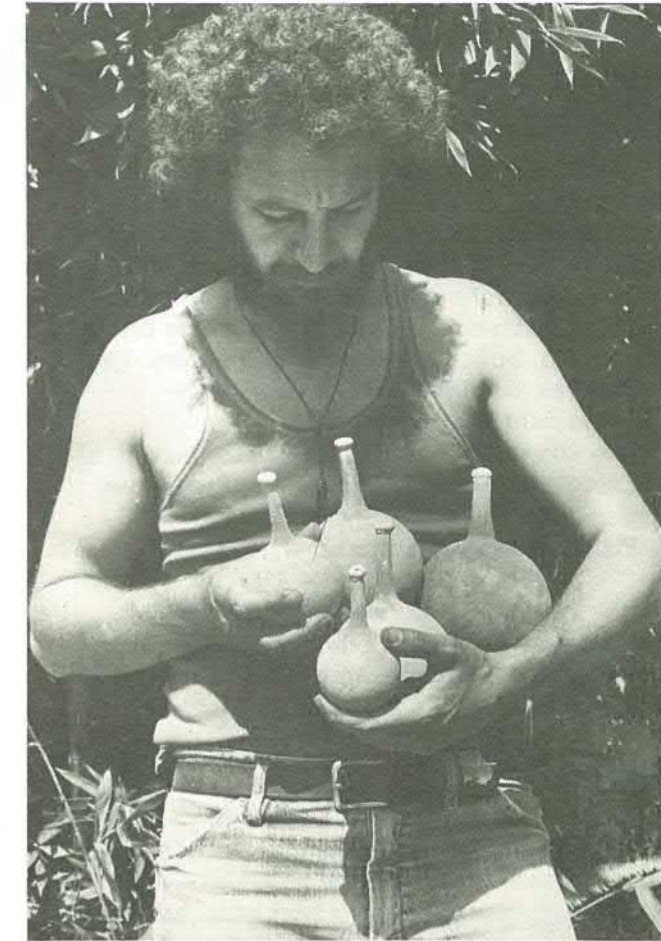



# Peter Stichbury's small one chamber kiln

This is a small, one-chamber kiln built to a two-shelf plan. The volume of the stacking section is approximately a cube in proportions. Note that the spaces between shelves, and shelves and walls is 75 mm (with minor fractions in some spaces to accommodate whole bricks for ease of building the walls of the kiln). The firing area is 150mm wide for flame development and movement.

The kiln is a simple box of bricks, leaving a wicket 3½ bricks wide and built to the following dimensions.

- Inside: Length 4½ bricks — 1025 mm
- Width 2½ bricks — 570 mm
- Height 11 bricks — 840 mm

Height is from top of floor to base of skewback bricks supporting arch. Arch is calculated on an angle of 60 deg (see diagram).

### Building stages:

1. Concrete pad of suitable size which could include an area in front of the kiln for ease of movement for the potter.
2. Lay two courses of common brick to the outside measurements of the kiln. Lay more courses if added height from the ground is desired. Level off with sand.
3. Lay three layers of firebrick, leaving the opening for the flue. (This passage is 225 mm wide and 150 mm high and is central in the kiln as shown in the plan). The top layer of bricks which becomes the floor of the kiln should be buttered with fireclay at all touching surfaces. The two passages for the burners should also be built in, and if the kiln is to be started with a pot burner, the port for this should be built at the same time. (see A, on plan.)

**NOTE:** To allow the floor bricks to cover the flue channel — edge the under layer of bricks 12 mm over the channel on each side, so that the full 225 mm brick can cover the channel. The top floor layer and the under layers of bricks are set in on the 75 mm face, so that these 2 layers are 225 mm in depth.

4. Lay one complete course of firebricks as the base of the kiln wall — set with fireclay. Complete the kiln 'box' up to another 9 layers of bricks leaving the wicket, or door opening, which is 3½ bricks wide. Where half-bricks have to be used at the edges of the wicket, set these in whole, with the other half at right

angles to the wall away from the interior of the kiln. The common bricks which form the insulation can be fitted into these when the insulation is added, which is the next step.

5. Build up the insulation with common bricks, leaving a small gap between them and the main wall. A very light cement mix can be used here. Use thickly to build up the height and length of the commons which are usually smaller than the firebricks. A mix of say, one cement to six builder's sand and six fireclay can be used. This is surprisingly strong. Make sure that the top layers of brick-fire-brick and common, are very level and even at the ends of the kiln.
6. Carefully set six skewbacks across the tops of these end walls. Make sure that the edges at the inside wall are parallel.
7. The kiln bracing should be fitted at this stage, as the arch cannot be built until the walls are secured. A careful study of the photographs will show how the bracing is added. Materials are light angle iron with welded lugs, drilled to take the rod (½") which runs the length of the kiln. Note that the channel iron supports directly behind the ends of the skewbacks which support the arch.
8. Fit the bracing loosely at this stage. Support the arch former in the kiln at one side — so that the ends of the curve are level with the points of the skew backs. The skewbacks should of course have a 60 degree angle.
9. The arch has 16 bricks to a course, as stated in the materials list, with nine S 12 (70 mm bottom face) and seven S 8 (64 mm bottom face) Huntly side arch bricks per course. Plan these out on the ground with a skewback at each end to see that the arch "forms" correctly before placing these in order on the arch former. Once carefully in place, remove the former and repeat across the kiln. Every now and then tap a set of matching bricks sideways until a half-brick gap is made — fit in another appropriate brick where whole bricks can be added, and half-bricks where necessary. This ties the arch together so that there is not a row of half bricks at one side of the kiln. When the arch has been set in, tighten up the appropriate bracing, and with a hammer lightly tap the bricks into a smooth curve. There will bound to be some bricks out of line when the first setting of the arch has been made.

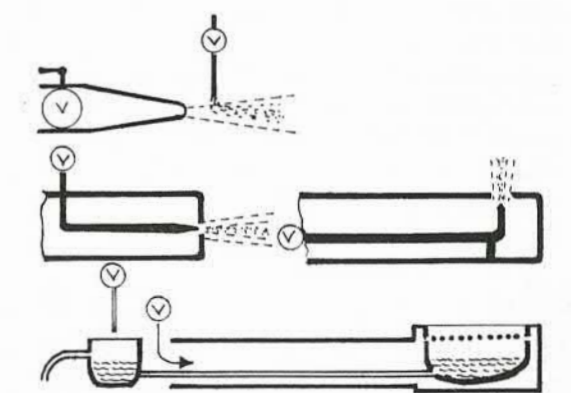
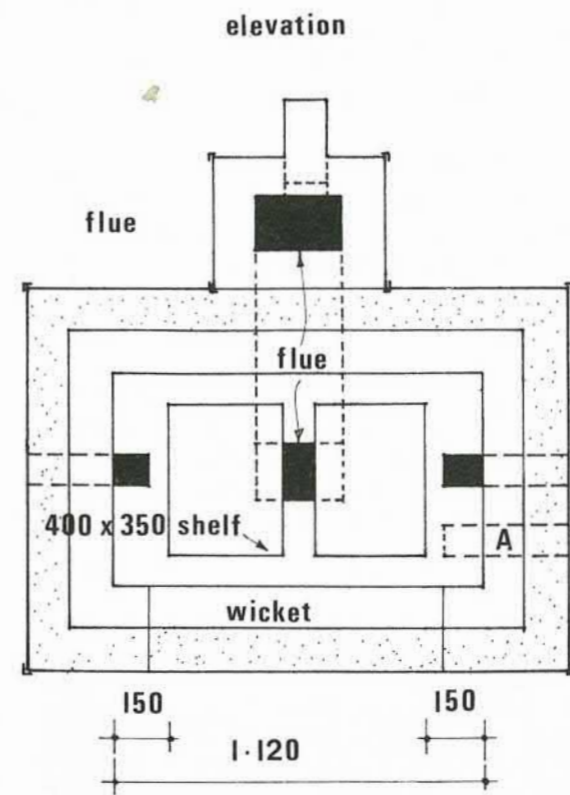
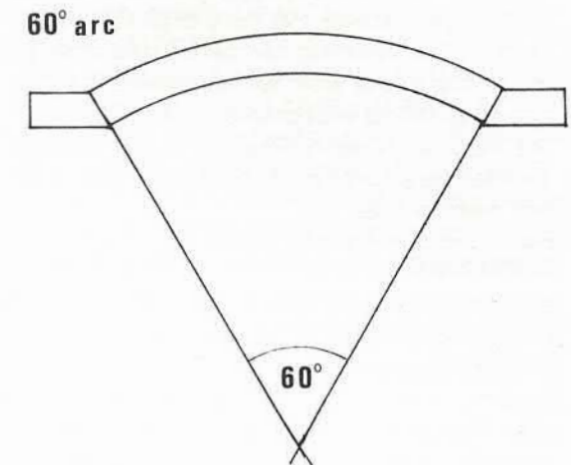
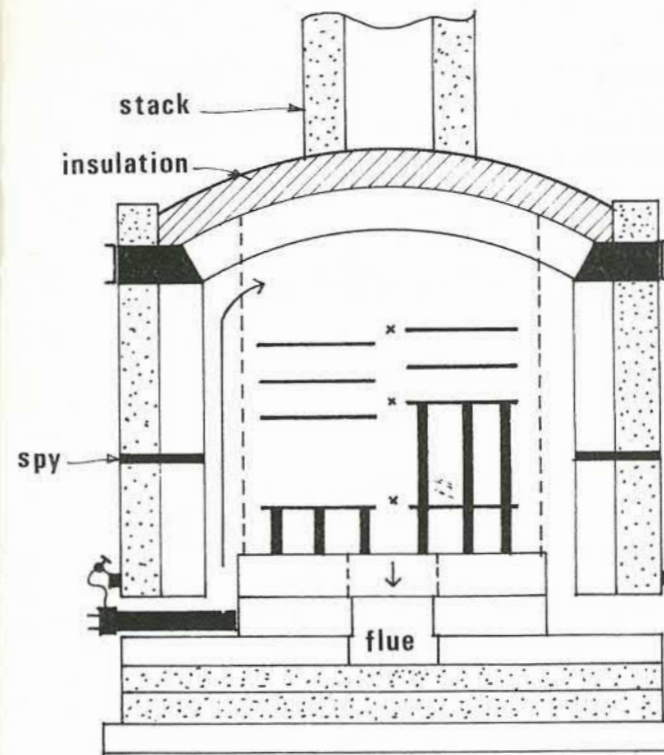

'blown drip feed' burner : top  
pot burner : below

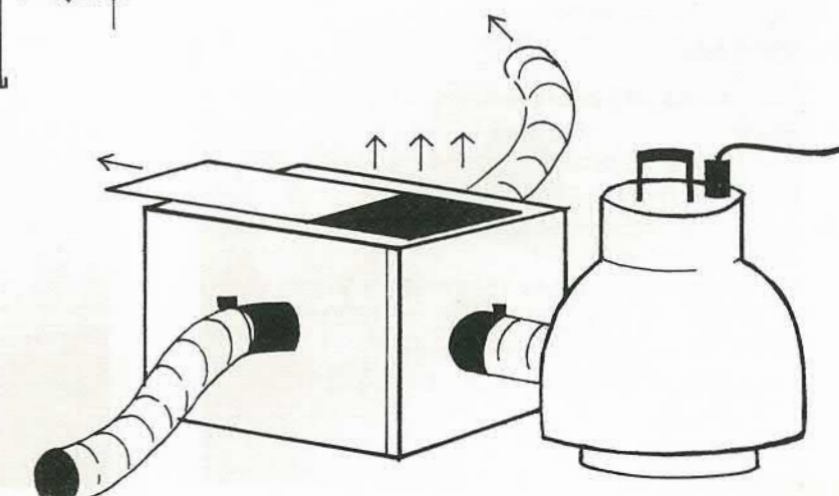

air regulator

Drawn by Karen Wiley



10. Complete the 'well' above the kiln — a brick in height above the top of the arch — two if required. At the wicket another arch can be built slightly lower (50 mm) than the main arch, or the opening can be carried right up to the top of the well, which means that the opening is filled with bricks right to the top of the main arch each time the kiln is packed.
11. Tighten up all bracing to firm tightness — do not overdo this.
12. Build the stack up to 3 metres. This can be to the top level of kiln in brick and then a 200 mm diameter steel pipe — or all brick — whichever suits. Brace stack with angle iron. Where the bricks conflict with the kiln bracing — cut in channels to allow rods to pass through. In the plan there is shown provision for a removable whole brick — about three layers up from kiln floor level. This is used during reduction to allow air to cool the stack, and thus decrease the flame flow and increase the flame pressure in the kiln chamber. A damper may be built into the stack also, or used alone if preferred. If a section of iron pipe is used to complete the stack, then it can be stayed with twisted wire to the outside corners of the kiln — to the bracing, and to a peg set in the ground a few feet away at the back of the kiln.

### General

The first two shelves in this kiln should sit on three props of 112mm (cut firebrick) in height. When stacking the kiln — keep larger pots on the bottom shelves, and on the top shelves, and stack all the smaller pots in between. The elevation gives an indication of this stacking. This allows flame movement through the bottom part of the kiln, and over the top. The pots in between have enough flame movement and radiation to make the kiln heat very evenly.

### Materials

Arch bricks. 3½ courses each of 9 x S12 and 7 x S8  
 Fire bricks. Approx 600 standard Huntly H30  
 Common Bricks. 1000 approx.  
 Angle iron. 4 pieces each 1400mm long, 38mm x 38mm x 3mm.  
 Channel iron. 2 pieces 75mm, each 92mm long.  
 Half-inch rod. 4 pieces each 1620mm long threaded 100mm both ends.  
 2 pieces each 1120mm long threaded 100mm both ends.  
 Builder's mix, sand, fireclay, cement.  
 Insulation - vermiculite or perlite.

### Equipment

Two jet burners  
 Two pot burners (optional)  
 Fan (commercial Tellus vacuum cleaner — second-hand — is suitable)  
 3.7 metres of 38mm flexible air hose.  
 Copper pipe — ¼" for fuel supply from tank, one at each burner.  
 Attach latter to end bracing rods, by means of copper supply pipe firmly clamped to it.

### Air control

Build a small box with a sliding lid. Two 38mm holes at opposite sides. Attach one 1800mm length of air hose to each. Fix fan or Tellus outlet to end of box with suitable hole made to allow influx of air. The sliding lid gives control of amount of air actually delivered through air hoses to burners. See diagram of this. It is easier to set small lengths of 38mm pipe into these holes so that the air hose can be clamped on to them, using hose clips.

The air is controlled by opening or closing the sliding lid of the box. The more the lid is open, the less air is delivered to the burners. Experience will give the potter easy control over this.

### Firing sequence

Kiln can be started by either pot or jet burners. Pot burners are started with a small cotton waste wick in the burner channel. No air is delivered to the burner, which should be placed in the port without the air hose attached. The burner will draw in its own air when lit, and the oil supply should be very light and the flame as clean as possible. When the burner is hot and burning well, air is introduced — very lightly — and air and oil increased as the kiln and burner area get hotter. If the change to jets is to be made — leave

Stichbury kiln at Palmerston North

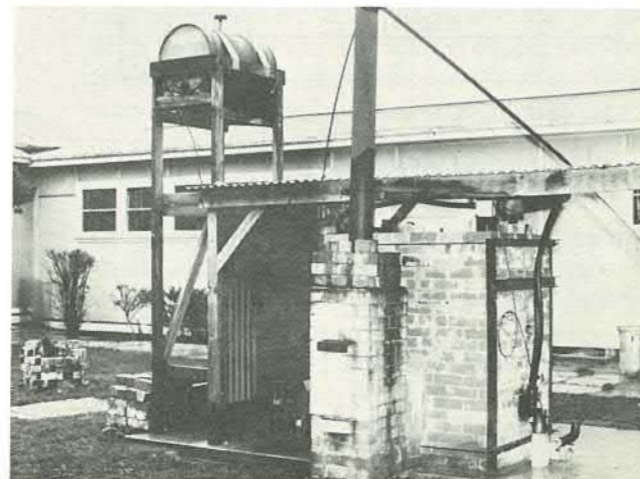

this until the kiln is showing good red heat, when the jets will take over very easily. Block the pot-burner hole with firebrick.

When using the jet burners to start the kiln the method is somewhat different. The jets are placed on their side supported on brick ledge level with burner port, with jet pointing into the fire port. A wick of cotton waste (soaked in diesel) is placed just inside the fire port. This is lit and the air and oil turned on very lightly — enough to spray the oil gently on to the wick but not to blow out the wick. The air and oil can be increased gradually until burning strongly.

Keep an eye on the ports, so that they do not fill up with soft carbon — but also keep them as full of flame as possible. After about two hours firing, when the kiln is red hot inside, turn down the oil, clean any carbon out of the burner ports, turn the burner upright (oil right off) and place right into burner port — turn oil up sufficiently, and pull the burner slightly back until the oil jet catches the edge of the firebox on the inside of the kiln. This ensures that the oil burns cleanly off the hot brick.

The kiln will rise fairly quickly in temperature at this stage and once it is seen that the flame is well developed, the burners can be pushed right into the port and left thus. Block off the secondary air going in above the burners with a prop or piece of brick. The flame should not be too fast or fierce, but should flow softly and fully through the kiln — more volume of air than pressure of air. When reduction is started — pull out the brick from the stack and adjust the oil to cope with the greater pressure in the kiln. This means turn it down, until a medium reduction flame comes from the spy-holes — with not too much black smoke from the stack. When cone 8 is half-down, the brick is replaced and the oil turned up. The secondary air can now be allowed to enter above the burners

Teachers' College photos: Stan Jenkins

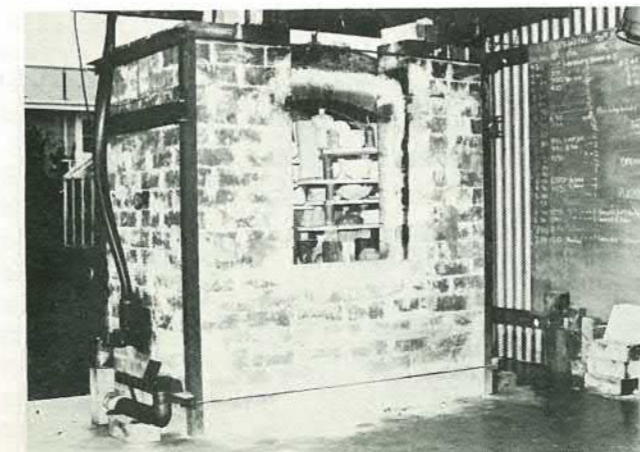

and extra oil given to cope with this extra air — which, however, is only slight.

Some experimentation will be required to fire the kiln very evenly. Do not expect perfect results after the first firing. Conditions vary with packing of kiln, amount of air supplied, speed of flame, weather. Place sets of cones at approximately the positions marked with an X in the elevation. Note the small spyholes built into the walls directly above the burner ports. These can be used to check the flame quality and quantity and to see that both burners are supplying equal amounts of flame.

To soak the kiln, reduce air and adjust oil to a soft, gentle flame.

### Cones to Use:

Top Cones 10 : 9 : 8  
 Middle Cones 10 : 9 : 8 : 6 Cone 6 is a helpful indication of progress  
 Bottom Cones 10 : 9 : 8

No set time is given for the firing cycle — average could be twelve hours. A similar kiln fired at Ardmore Teachers College a few years ago took either nine hours or up to fifteen hours, depending on the stacking and other conditions mentioned, and which student was firing it!

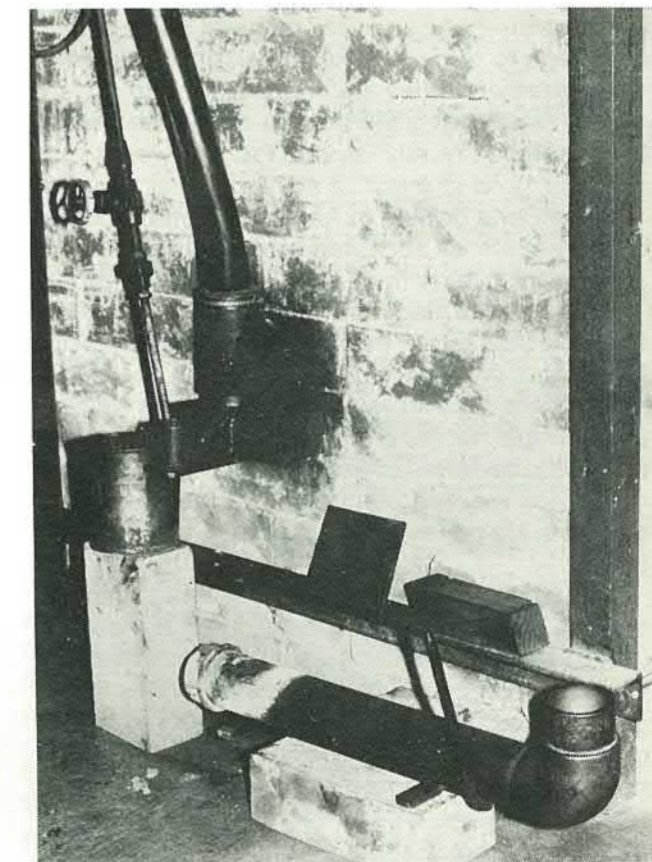



# Raku Makers



**Nancy and Bill Malcolm**

In America, Raku is common. But it tends to be the stuff of holiday workshops for potters or a flashy and effective introduction to ceramics for varsity students in the arts — “from digging clay to finished pot in the same day”.

By contrast we're attempting the unlikely marriage of Raku with classic thin-section thrown ware, hoping for pots that are truly functional but colourful and delicate. We chose delicate pots because they feel good in the hand and are a challenge to throw on the wheel, not because we've tired of stoneware. Indeed, we find ourselves admiring the thrown dinnerware that New Zealand is justly famous for, and want to try our own hand at it out of envy.

Some Raku potters in America claim that Raku is a way of life, an acceptance of the unexpected, looking for beauty in earthy, common things. Their ware, like traditional Japanese Raku tea bowls, is built rather than thrown, and often is not functional. We would be embarrassed to claim such mystic rapport with Raku, although we do prize simple forms, and the unexpected in Raku firing. It's inevitable anyway. We've borrowed little more than the firing technique of the Raku tradition. Many New Zealand potters by now have tried it.

With tongs a pot is put into a red-hot kiln and left until its glaze surface is glassy. Then the pot is lifted out and smoked in oil-soaked rags or leaves. Most combustibles will do. Metallic oxides in the glaze are reduced where the fuel touches the glaze. Oxidation effects are added by pulling the pot out of the fuel while it's still hot and exposing it to air. Then water-quenching freezes the mixture of effects. It takes some practice to recognize

colours when they're dulled by the high heat of the pot. As a result, sets of pots often suffer from glaze variability.

We fire with oil, but electric kilns give more even results, although the repeated thermal shock of opening the kiln is said to shorten element life, as does glaze splatter during the firing. Traditional Raku firing temperatures are low, and the glazes are usually based on lead. Because we wanted functional ware, we've avoided lead, even frits, and finding suitable glaze formulas has taken a long time.

We sell only through shops, having sought out a rural life to escape population pressure, and knowing that visitors would leave us with little time to work. We're happy with the best pieces coming out of our Raku attempts, but losses have been high and still are, often 70%, inevitable with the rigours of heat-shock and water-quenching during the firing.

We emigrated from the New York area in 1971, driven out by population pressure and its pathology of traffic, prices, pollution and frenzy.



Not that New York isn't exciting — it's where “everything's happening”, but the dollar and psychic cost of getting at it all is too high. We want an unspoiled environment that doesn't always lean on us. To that end, we've shifted to a sunny rural valley near Nelson, and are breeding dairy beef for export. We're relaxed and happy in New Zealand, and would not return to America.

Nancy holds a Master's in ceramics from Rutgers University New Jersey, having studied with Hui Ka-Kwong, who makes brightly coloured hard-edge sculpture-pots. But we were not production potters in America. The market there is either through galleries for kinky arts stuff (strictly non-functional ware like heavy funk, sometimes



**Denys Hadfield**

Few potters seem to be interested in working in Raku to any depth. So far my progress has been slow. I've built one Raku kiln from a mixture of refractory materials which are suitable for casting a shape which is aesthetically pleasing.

Out of this kiln have come sixty pots using differing clays to find a clay body which can stand up to thermal shock and the rapid cooling. I also wanted a suitable clay colour — white. Several formulas have been tried until a working knowledge of the material has been obtained.

With the aid of a Queen Elizabeth II Arts Council Grant, this year I'm working on kiln design. I'll be building two more kilns for different shaped Raku pots — tall pots, larger platters and averaged sized bowls. Also I want to find ways of reducing the larger pots inside the kiln, and be able to immerse them in water while still red hot. I'm experimenting in the construction of light weight Raku kilns using a special castable material which makes construction quick.

not even ceramic), or craft-fairs (traditional stoneware and earthenware, of varying quality). Most people there buy ceramics for art-investment or as with-it tokens of membership in the back-to-earth movement. Rarely do they buy for use. In New Zealand, far more people buy pots for everyday use.

After we settled in Nelson, Nancy continued her potting, and especially Raku because she enjoyed the colourful glazes it can produce. She sold some pots locally and then more widely. Finally she drifted into modest production. With the bottom out of the beef export schedule, the pottery is assuming more importance to us.

*Sunday Creek Pottery  
Wakefield, Nelson*

My first real contact with Raku was during an Australian visit in 1972. I met up with a potter in Queensland and did some work in Raku with him. I began to see great possibilities for creative expression through Raku.

After years of learning and gaining knowledge in more conventional pottery, here was an aspect of the craft that showed me things. Raku pots had elusive qualities — qualities not created by planned methods but by other spontaneous factors.

Back in New Zealand I found that a change in my personal direction was necessary. After years of potting in peaceful countryside, I moved to the city. It took me nearly a fortnight before I could sleep at night, such was the contrast from the quiet country.

To my amazement I soon found an old brick building suitable for a studio almost in the heart of the city. The landlord was a blacksmith. From this studio has developed the Artist Quarter where



there are now a weaver, a screen printer, an artist and two leather workers. In our studio we've rebuilt the trusty 50 cubic foot and a 30 cubic foot kiln. My brother Philip, who is showing the necessary dedication and skill to be a potter, helped with the building.

Raku techniques can be suitable to the novice potter and I plan to use this approach to pottery with school students and with adult groups.

I have come to Raku the long way round. In 1964 I first started taking art lessons from John Coley in Christchurch. A piece of stoneware by Bernard Leach used as a still life subject was new to me and it captured and held my interest. Later I worked with Marion Mauger learning the basics of earthenware. Then in 1966 I started with Yvonne Rust in her studio in Christchurch and had a wonderful time gaining insights into stoneware.

Shoji Hamada visited Christchurch. Watching him working at Yvonne's studio had a profound effect on me, and my attitude towards stoneware changed.

After a year with Yvonne I decided it was time to build and fire my own kiln. I started with Roy Cowan's 50 cubic foot kiln using his low pressure burners. (I have yet to see a more suitable stoneware kiln). The next 18 months were spent perfecting the firing method. Then I made the decision to forsake all and go potting.

Thirty miles north of Christchurch in the heart of prosperous downland farms was Philip Coleman's 120 year old homestead. I bought it. It had been empty for three years, but was built of 80lb sod blocks and rimu rafters so it was sound. It was two storied with six bedrooms having been built by the Colemans as an accommodation house for horsemen travelling north. The house stood in an English garden of flowering trees. Here I built two kilns, one for glaze and one for biscuit firings, and got working.

The next four years was spent learning the discipline of throwing runs of domestic ware and finding a suitable range of glazes for them. It has given me great satisfaction to create, to form, to plan, to bring to life an object which carries one's fine sensitivities. The expression of these inner feelings brings love and joy into life. All this is in total contrast to the current worldly motivations for consuming and greed with little respect for the real needs of humanity.

Some say "no point in making Raku because it's so fragile". But this very factor has its own advantages. It has less power to exalt the human ego because of its usefulness. It's possible to super refine it, but I believe the real message I get is from blacked, smoked bodies, white crackled glaze, bands of rich reduced copper and pleasing

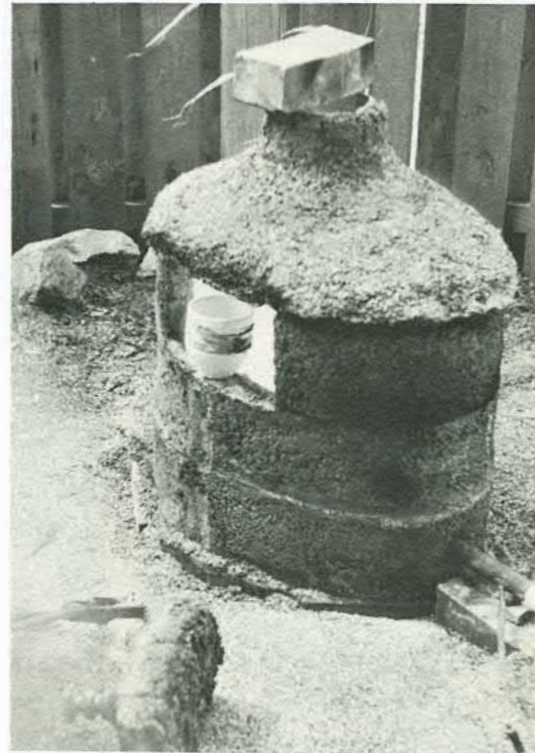

Raku kiln, number 1, temperature 900°C. The pot on the wicket is ready to go in.



imperfections. It teaches me things and always makes its own final statement."

## What is Raku?

During the first half of the 16th century, a type of earthenware, ever since known as Raku, was developed. The first Raku potter was Chojiro who was the first of a long continuing line of hereditary Raku master potters down to the present Raku XIV. There has been, for many years, an interest in Raku techniques in New Zealand and to some extent this has taken the form of community efforts at pottery parties.

It has been suggested that there are some who regard Raku as something made in the Xmas barbecue. I might reply to this that a few people who are making what they call Raku are merely making low fired earthenware. It is certainly a technique well worth investigating and perhaps developing, but I have certain reservations.

I do not believe that successful work is ever produced completely at variance with its own period. Some may argue that a great artist produces from his own mind a vision that influences a period and lays down the style of that period. I prefer to believe that the artist distills from his surroundings and time its essential essence, and puts it in visual form.

Thus a soft paste Worcester vase is a laugh in a 1970 pottery art shop, Braque, in 1700 would have been incarcerated, and Thackeray is hard reading today.

Raku ware, which mainly consisted of bowls, arose purely through the demands of the tea ceremony. This extremely stylised procedure of drinking tea provided a time for leisurely gossip, for relaxation, and for discussion of surroundings. The tea bowl provided fuel for this, and the range and subtlety of the observations upon each bowl would be completely beyond the comprehension (or patience) of most people today.

These discussions would cover the form, the texture and colour, the qualities of heat transmission, the feel of the rim on the lips, the physical balance of the pot, and the techniques of manufacture.

The pots were, of course, hand built.

In addition to this, Japan was a closed society — nearly all contact with the outside world was cut off and art turned inward. This had the effect of crystallising art forms.

This then, was the condition under which Raku flourished. Indeed, there is a Japanese belief that no great Raku was made after the 17th century.

A further point of interest is that Raku was always a great dilettante exercise in Japan. Wealthy sons would make tea bowls in a dabbling sort of way.

I see no great place for Raku in today's world other than an interesting exercise often producing unexpected and very beautiful results. It provides an instant appreciation for the new potter of the qualities of clay and glaze under fire, but a sentimental journey back to 17th Century Japan is not justifiable.

**Trevor Bayliss**  
Auckland Institute and Museum

## ATTENTION SUBSCRIBERS

The answer to many subscribers who have asked if it is necessary to have prepayment of subscriptions, is "yes." The Potter's circulation has more than trebled over the past four years and we cannot assume that you will all want to renew.

A renewal form is enclosed with this issue. It would help us if this were returned with your remittance now or early in the new year. A receipt of acknowledgement will be sent only if requested. Where cheques are sent this is not necessary, but we would ask that these people tell us if their cheques are not presented within a reasonable time.

We aim to have the Potter published by June 30, and Nov 30. Allowing time after that for mailing, it should be in your hands by mid-July or mid-Dec (later for overseas subscribers because it is sent surface mail.)

## Early potters of Mexico

There is a strongly developed aesthetic sense in the Mayan pottery that I saw in Mexico. Decoration was rich and varied. Sculptured figures and sculptured forms were used in many diverse ways.

Before the Spanish conquest the potter's wheel was unknown to the Mayan craftsman, vessels being made with moulds of clay or modelled by hand. This may account for the great variety of sculptured motifs which include jaguars, dogs, monkeys, birds and serpents as well as men and mythical monsters.

Mayan potters seemed to have excellent technical knowledge and they produced big and elaborately modelled ceramics. Often these had a religious purpose. Incense burners and other vessels of great size, beauty and technical brilliance were produced. Many unglazed pots were painted with gay colours and they show a strong sense of design.

The potter always seemed to create a shape even if unembellished with sculpture or graffiti in which grace and functional purpose combined. These qualities together with wit, liveliness and humanity, made the Mayan potter a very real man to me.

*From Lorna Ellis's notebook*

## School Pupils exhibit

The most outstanding achievement of the South Wales Potters as a society last year was the staging of the "Ceramics in Schools" exhibition. This was one of the most ambitious projects tackled by the S.W.P., and of a new kind — using our corporate capabilities to promote the work of others. One thousand pieces from two hundred recommended secondary schools all over Britain (Orkney Isles to Isle of Wight) were assembled and displayed. Five pots were sent from each school but there was no selection of these and no theme. The first exhibition of its kind, the range of ability and expression must have been an eye opener to many people and is a tribute to the teachers concerned. This lively show was mounted in Cardiff, London and Glasgow.

*Janet Hamer, Newport Gwent, Wales*



# 4 generations of potters

by Jan Bell

Te Mata Potteries, kingdom of the Fulford family for more than 50 years, is a historic landmark in Hawke's Bay and the symbol of four generations of potters. Now its kilns are cold, and the large drying sheds which once held 28,000 flower pots, contain only hay and other storage.

The pottery began when Huelin Fulford bought back his old treadle wheel which he had sold before World War I, and in 1923 he began making pots for fun. But what started as a hobby soon grew to be a business.

As a potter, Huelin Fulford was certainly born to the craft and his inherited knowledge of pottery was widely respected.

His father and grandfather were both potters. John Fulford senior made bricks in Jersey, Channel Islands, and Huelin's father, John junior managed a brickyard in Granville, France. It was in this yard that the pipes for the first Paris sewers were made. At the outbreak of the Franco-Prussian War he returned to Jersey and it

was then the family decided to come to New Zealand to manage a brick yard at Napier.

John Fulford Jnr moved to Havelock North eventually, and set up his first business a few chains down the road from the present site in Te Mata Road. This business seemed fated and an earthquake terminated a spring which provided water for the pottery.

In 1892 John started again, this time in Joll Road, Havelock North, near what is now the shopping area, and clay was excavated from a large area right up to the Anglican Church. The factory was commissioned to supply bricks for many buildings which were later devastated in the 1931 Napier earthquake. A million and a half bricks were used in the Grand Hotel, then considered a skyscraper at four storeys high. Fulford bricks were also used to build the floor of the T.M.V. Vineyards plant — one of the oldest in N.Z.

Work with clay at this time was very heavy, with little mechanization, but John was fortunate in having the help of a horse named Ned. Ned's job was to pull the trolley of unfired ware from the drying sheds to the kiln and he knew the route without human aid, but there was a drawback, sometimes he failed to appear as usual. Eventually someone would have to investigate, and sure enough, there was Ned having a quiet snooze in

the only spot out of sight from either end of the proceedings.

At the beginning of the 20th century there were at least four other brick and pipe works in the area, so eventually the market was over-supplied, clay became scarce, and in 1915 the Fulford brothers dismantled John's factory.

A much cherished family possession is a large urn, made by John about 80 years ago. It has two snake like handles and is made with a buff clay taken from the vicinity of Cape Kidnappers.

After World War I, Huelin Fulford established Te Mata Potteries, and for many years thousands of flower pots were made by machine. Several workers were employed including three of Huelin's sons. At peak capacity the pottery was turning out 15,000 pots a week, made from local red clay firing at 1050° centigrade.

Huelin concentrated on hand thrown bird baths, garden urns and some glazed earthenware. All sizes and all shapes were supplied to nurseries throughout New Zealand and the pottery became known as the home of earthenware.

Huelin designed and built several kilns, his first was very small and was soon replaced by a much larger one. Unfortunately this was partially destroyed the day of the 1931 earthquake. The kiln had been fired the day before the quake and was

still full of hot pots when disaster struck. He then built what is still probably the largest down-draft kiln in Hawke's Bay, at first using over one ton of coal for each firing, but later converted this to an efficient oil burner system.

Then sad times again fell on the pottery. With the advent of plastic the demand for clay pots declined as plastic flower pots replaced the earthenware. The Fulford sons turned to other occupations, but Huelin continued to produce hand thrown gardenware and glazed earthenware until his health forced him to give up regular work, and in 1970, at the age of 79 he died.

Huelin Fulford became well known as a potter of merit, one who loved his craft. He was always willing to demonstrate to visitors who often used to come by the bus load, or to help aspiring potters. In his opinion a person could only be taught so much. "It is all in the feel", he said, "pottery is something which is in your blood, but a man is not a potter until he can turn out a row of pots and see they are all the same". The youngest son, David, then took over the family pottery, as a 4th generation potter. He continued the Fulford tradition and was well known for large garden and patio urns, but early in 1974 he closed Te Mata Potteries. He hopes to establish a studio on his own property some time in the future.

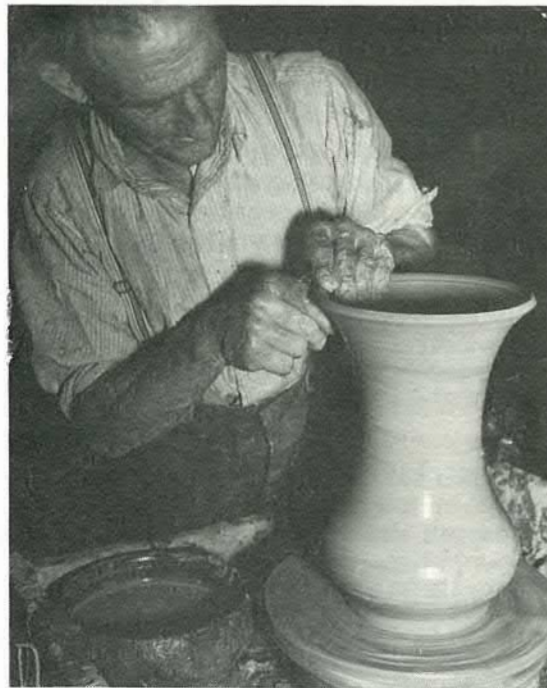

Huelin Fulford

one of the first in Hawke's Bay

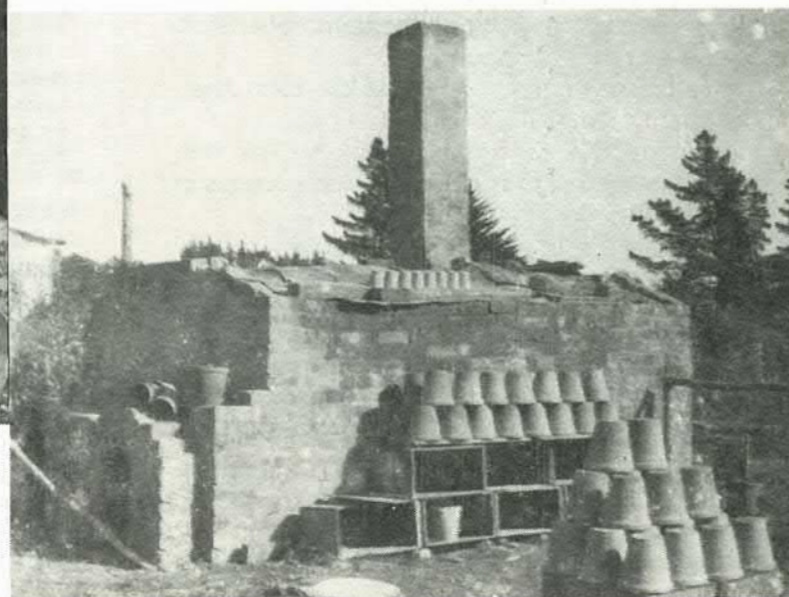



## POTTERY KILN PYROMETERS

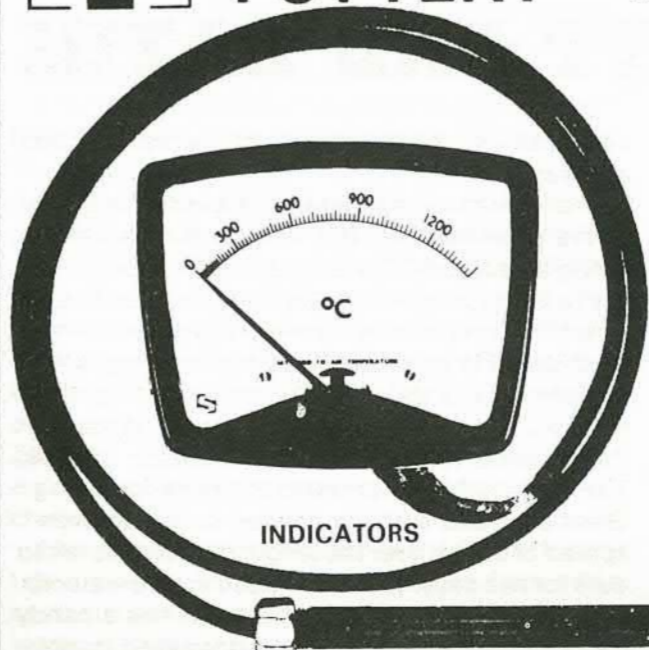

**INDICATORS**

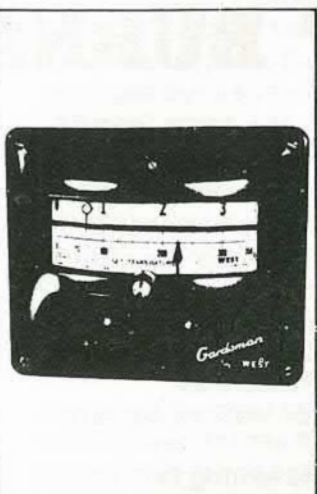

**GARDSMAN CONTROLLERS**

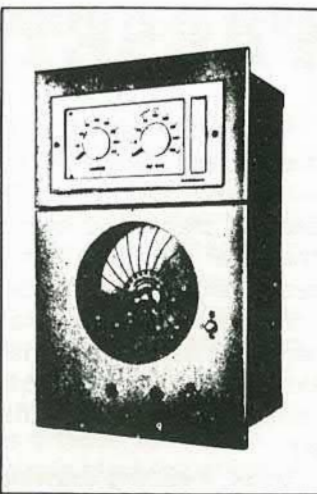

**PROGRAMME CONTROLLERS**

**TEL THERM INSTRUMENTS LTD**

419 KHYBER PASS ROAD, NEWMARKET,  
AUCKLAND 1, NEW ZEALAND.

P.O. BOX 9575, AUCKLAND, 1.  
TELEPHONE: 545-065 (5 LINES)

BRANCHES: WELLINGTON, P.O. BOX 1624, PH. 50-667.  
CHRISTCHURCH: P.O. BOX 1267, PH. 65-091.



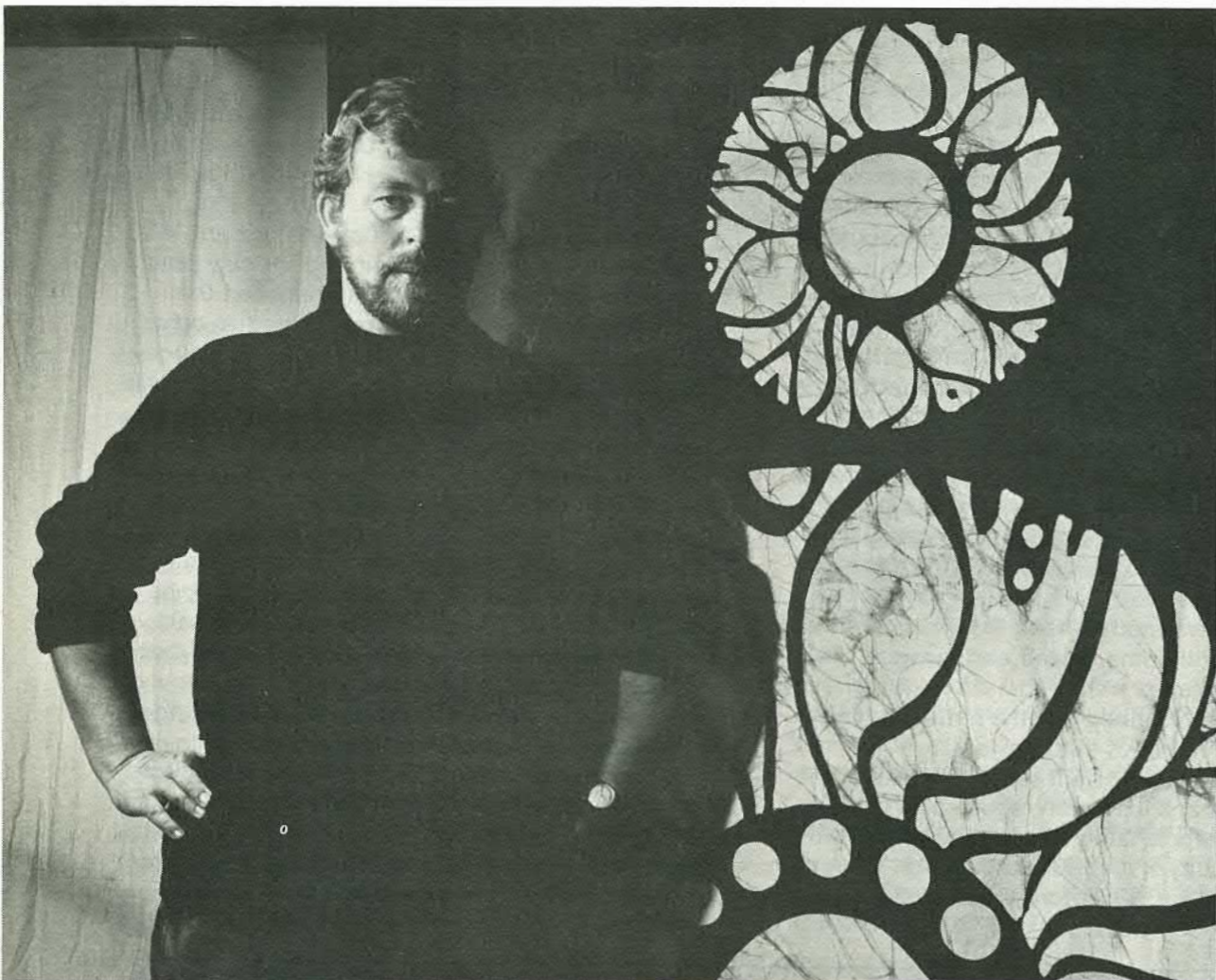

## FASSETT BURNETT AND BATIK

Fasset Burnett of the Bay of Islands, practices this ancient Javanese craft. The technique is Indonesian, but the designs are inspired by New Zealand plants and animals so his batik has a character of its own. Fasset Burnett is one of our best interpreters of Maori motifs.

He is a craftsman with a fine sense of design. His hangings have been outstanding exhibits in craft exhibitions. They are equally usable as bedspreads or tablecloths or on walls as works of art.

Batik, meaning drawing and writing in Javanese, is a process of wax resist dyeing. It has been practiced as a craft in Indonesia for centuries but the method of decoration was also known in India, Europe and parts of Africa. Batik prints in the last few years have been found by the fashion promoters.

The process is a direct way of making design on fabric. Fasset Burnett draws on the fabric with hot liquid wax. Then he paints on the dye which is

absorbed only by those parts of the material that are wax free.

In preparation, the material is washed to get rid of the dressing, then it is stretched on a frame. Using a traditional Tjanting, a small copper kettle with a long spout, the hot wax is painted on freely. Fasset Burnett makes no use of blocks or stamps. Each piece is original. When the drawing is completed it is taken off the frame and lightly crushed to crack the wax. The dye penetrates these cracks to give lines characteristic of batik. The fabric is then returned to the frame for drying. Great care and skill are needed to get an even spread of colour over the length of batik. It is left to cure for two days. Then it is rinsed in cold water to remove excess dye. Fasset Burnett has a handy creek for doing this. Finally it is washed in hot soapy water to remove the wax. The waxing and dyeing process can be repeated giving additional colour to enhance the fabric. It all amounts to a good deal of handling.

Fasset Burnett left New Zealand in 1956 for Java and became interested in the batik process in Jogjakarta. Later he went to Europe and there married painter Huia Rowlands.

"By 1964 I had had enough of being away from New Zealand. Living in other people's countries is fine, but somehow the hills are never quite the right shape and no matter how delightful the people, you never quite feel that you belong.

In 1965 we returned home. Huia and I had both painted in Spain, but when we came home any urge to paint deserted us and I began to make some batik dress lengths and work on the wharf at Opuia. In many ways we were back in the same position as we had been in before we left New Zealand — getting by on a shoestring and not entirely committed to making a living out of craftwork."

Like so many of our craftsmen the Burnetts have taken over an old house. This provides them with a spacious and interesting environment in which to work and they become caretakers for part of our historical landscape. "The house at Clendon Cove, Russell, Bay of Islands was built in 1842 by James Reddy Clendon. It is not as grand as some of his other houses and has been added to untidily

over the years, but we are slowly getting it tidy and planting trees in the eleven acres surrounding us.

On the property there is a Maori Pa site and the creek that runs into the bay is just large enough for us to get our yachts into. I have an old boat "Mirage" which was, in her day, one of the fastest 22ft racing yachts in Auckland.

Our son Tom, sixteen, has an eighteen foot cruising yacht that sleeps three which means that he doesn't have to put up with his old father when he and his friends want to get away for a few days. The reason for having two yachts in one family is that the correct management of small craft seems to excite fiercer and more bloody disagreement than anything else I can think of. I found that when Tom crewed for me it was difficult to restrain myself from giving a steady rain of advice which of course takes a lot of fun out of the game. With his own boat he can do things his own way.

After moving down to Clendon Cove we really got busy with batik and made a great many dress lengths. We used a front room of the house as a small gallery and sold sufficient to cope with the bills. But making dress lengths for the prices that people will pay is not a way of making a living, as the outlay in material is too great.



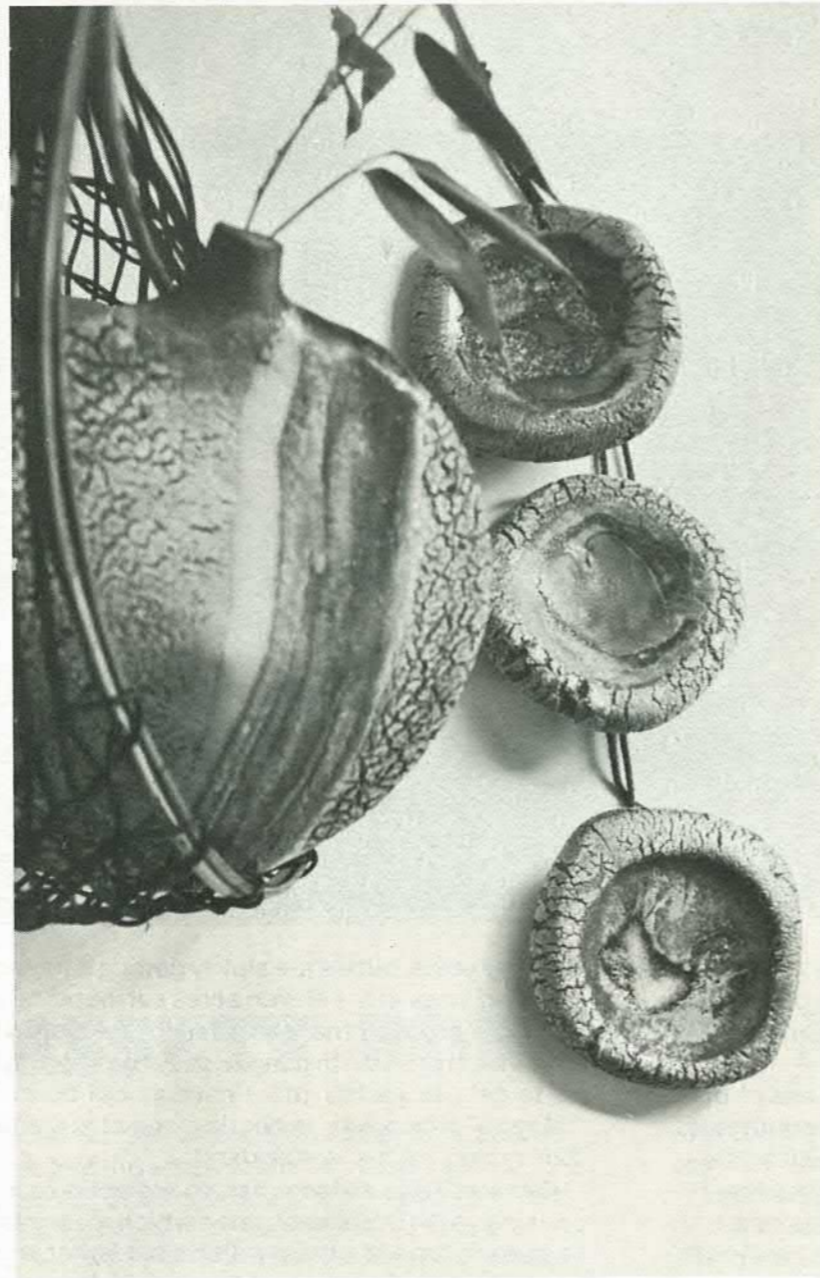

high quality pottery, prints and handcrafts

**V** Van Helden  
Arts & Crafts

Days Bay beach, Wellington P.O. Box 41-031  
EASTBOURNE Ph 8191 Open 7 Days a week  
11am/5pm

I had been making some wall hangings as well as the dress lengths and I was asked to exhibit in Canberra. The show was a success and we went on making ever greater numbers of wall hangings. There were other exhibitions.

The boy who had been working for us left to get a job on an oyster farm, so I decided to take a change of direction. Our property, because of inflated land values had become valuable so I decided to borrow some money from the bank on a mortgage and give myself a year making only what I wanted to make. I have concentrated on wall hangings and Huia and I are both painting again. Being able to spend forty hours on one hanging has made a lot of difference to my whole attitude towards batik and I realise now that the production routine I got into was a mistake.

I've just had an exhibition in Dunedin. It took me three months to draw, working eight hours a day for six days a week. I made twenty-nine hangings. I scrapped eighteen of them. The eleven that remained just filled the Moray Gallery and hanging them was a satisfying job.

This last year without the stresses of employing someone it has been easier to come to terms with what I really want to make, and now, having a clearer idea of what I am trying to do perhaps I won't make so many mistakes or head off in so many wrong directions."

*Some of Fassett Burnett's notable commissions include a 34ft hanging for the new telephone exchange, Canberra, and one for the foyer of the Mercury Theatre, Auckland.*

**Margaret Harris**

#### The Burnett batik process

Now I am printing on a good solid canvas. I have ceased cracking the wax as I think that for wall hangings the characteristic 'crackle' of batik is too fidgety and that the designs should stand up without it.

I use procion dyes which can be obtained from ICI. I mix the dye with water into a thick paste and then dilute it to whatever strength I want.

I paint the dye onto the waxed canvas with a brush.

Before painting on the dye chemicals are added as fixing agents. The recipe is:

5 lbs urea to 2 gals water  
½lb washing soda and ½lb baking soda to 2 gals water.

I store the liquids in ½ gal flagons and just before putting on the dye I add equal quantities of each liquid.

This is a safe and sure recipe. To be quite sure of fixing, the fabric should be left for two days before washing in boiling water with plenty of Taniwha soap powder.

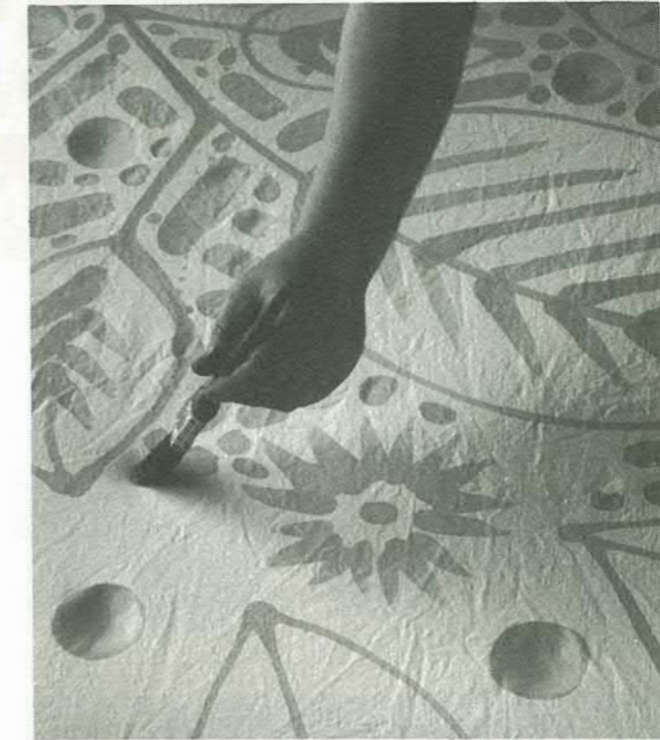

*Drawing with hot wax*



*painting on the dye*



# EXHIBITIONS

## ANDREW AND JEAN VAN DER PUTTEN

### Andrew van der Putten

Born in Amsterdam. Came to New Zealand when he was 20. Worked with Len Castle, Helen Mason and Jeff Scholes. A fulltime potter. Lives and works in Auckland's Waitakere hills.

### Jean van der Putten

Born in Kuala Lumpur. Came to New Zealand when a child. Studied at Elam School of Art. Began working with clay in 1969 because she married a potter. Works fulltime as a potter herself and as the mother of three young children.

In something like 20 years New Zealand pottery has transformed itself from a twee hobby to a secure and flourishing cottage industry.

The humble stoneware coffee mug makes a perfect symbol of change. Once a treasured cult object, it can now be found rubbing shoulders with utility cups on most office tea trolleys.

In many ways taking homemade pottery for granted has been a good thing. The old battles that used to rage in the '50s about whether pottery was an art or a craft are seldom heard nowadays. Likewise the equally fruitless rivalries between "amateur" and "professional" that used to cloud the pottery scene in a fog of bitchiness have vanished.

All that is on the credit side, but there has been a loss along with the gains. With bare exceptions New Zealand pottery is bland and boring. Each new pottery exhibition is predictable. The level of craftsmanship is generally high but that of aesthetic stimulation is low. The acres of small brown and grey pots that line the display stands at pottery shows are all, no doubt, useful additions to the kitchen cupboard, but they do little for the spirit.

In this climate the appearance of a young potter like Andrew van der Putten, whose first major show is at the new Alicat Gallery, is more than welcome.

Significantly van der Putten has not emerged suddenly out of thin air. He is very much the product of the best influences and directions within New Zealand pottery. He has served a valuable apprenticeship, working with Len Castle and firing with such competent potters as Helen Mason and Jeff Scholes. From his work it also seems obvious that he looked carefully too at the work of Barry Brickell.

With this kind of background it is not surprising that van der Putten begins to combine in his work the careful craft and kiln management of the best domestic potters with the spirit and inventiveness of innovators like Castle and Brickell.



From the latter he has learnt that the nature of clay is plastic and that its plasticity must survive the processes of the kiln. His forms are very much alive. They move and surge still in much the same way they originally took shape on the wheel. Van der Putten doesn't force the clay to death, but lets it live. If one thing is the mark of good pottery it is this. No matter how carefully wrought the form may be, or expert the glaze or inventive the decoration, the basic element that moves the imagination is the plastic nature of the clay.

In an uncanny way the volume inside van der Putten's larger pots seems to go on shaping the form. It is as if the clay had been laid round something else — some living thing perhaps. Where the potter needs to assert his final word he does. In the attachment of handles, in rims, in hands and feet, van der Putten firmly pins the pot's overall form in place. The best examples of this are in the strange knobbed and lipped bowls (a form derived and developed from some of Castle's more recent work). The scooped-out-lip in these pots is balanced by a solid base to the knob protruding into the bowl's internal space.

In many ways balance is the strongest element in van der Putten's formal imagination. He works like a juggler. His glazes are rich and once again these come from the pottery mainstream, but are taken a step further by his use of them.

The potter shares his exhibition with his wife Jean. This is more than a domestic arrangement, since Jean van der Putten is a competent potter in her own right.

Her pots are bound to be overshadowed by his. As yet she does not work with the same spirit, but there is one element in her work which deserves comment — like few potters here she seems determined to prise pots loose from the monopoly of the wheel and express a more basic joy in handling clay.

Perhaps Jean van der Putten could be regarded as still serving her apprenticeship. If that is the case, she could hardly have chosen a more lively, talented or spirited tutor.

Hamish Keith

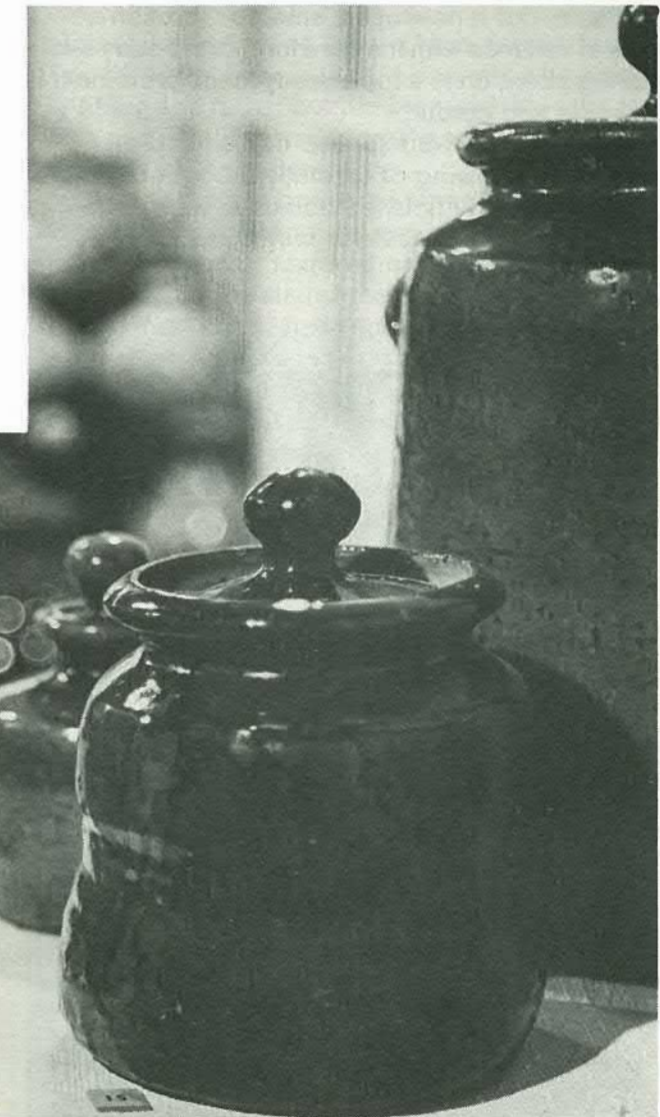
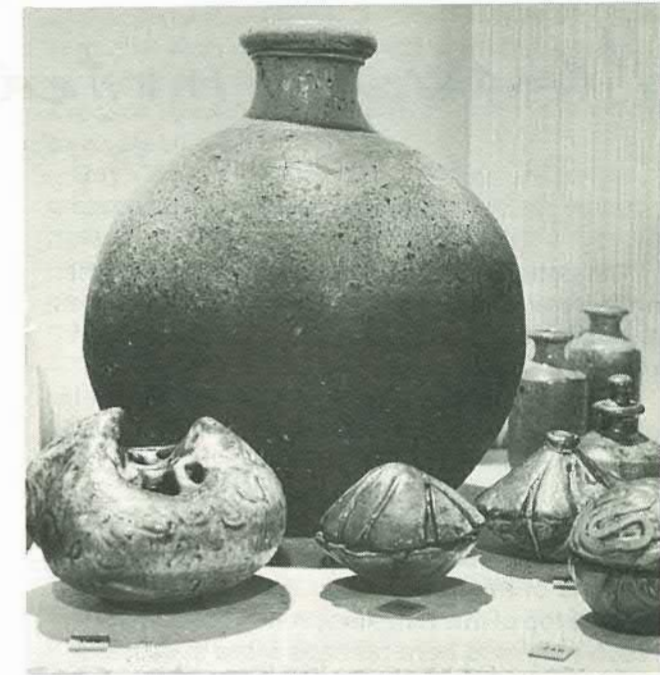



# Manawatu invited potters exhibition

The potters invited were each to ask one other potter to also take part, which is as good a way as any I suppose and the resulting exhibition was both varied and interesting.

Margaret Milne's work is always consistent in quality and restrained in character. Her porcelain; a fine bowl, a lidded box, a small, pale blue bottle and trio of small, pebble-textured cylinders were all beautifully crafted. She also showed a large bowl and a platter, both with thin, rather dry, rims, and one of the now familiar fissured pots. I feel that the top of this form has yet to be satisfactorily resolved — it is here perhaps more successful than the split fish-tail top on a similar pot shown at Dunedin, but it now has a stunted, "broken-off" look at variance with the pure form of the body and calling attention to a top already made prominent by glaze and colour.

Mary Hardwick-Smith also had an entirely consistent showing of carefully thought out and equally carefully finished domestic ware, the glazes pleasantly tactile in muted, yet rich, colours.

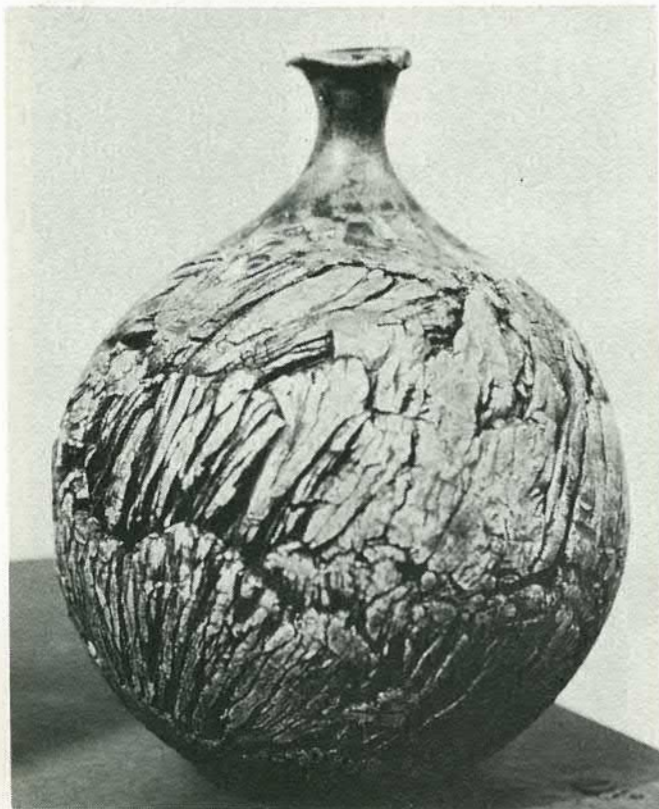

Margaret Symes showed her interest in form and texture in her handbuilt bottles. The "dry-grass pots", globular and heavily textured, were very successful but the groups of elongated, spindly bottles balanced precariously on small bases. For me the least satisfying piece was the thrown bowl with a deep blue centre and a roughened and harsh manganese-washed rim — its apparent ruggedness belied by an unctuous "bottom-of-the-kiln" yellow foot.

Howard Williams is primarily a decorator. He casts his simple forms in wafer-thin white earthenware and uses a variety of interesting techniques to embellish the surfaces. His tall, black, cylindrical lampbase, pierced by a series of radiating holes was effective and the square vase with the feather motif was delicately decorated. On the other hand I felt that too much had been attempted on the salad bowl.

Anna Gandy showed some vigorous, freely thrown pieces. The salt-glazed bowls had a rugged honesty about them.

Brian Gartside exhibited press-moulded bowls

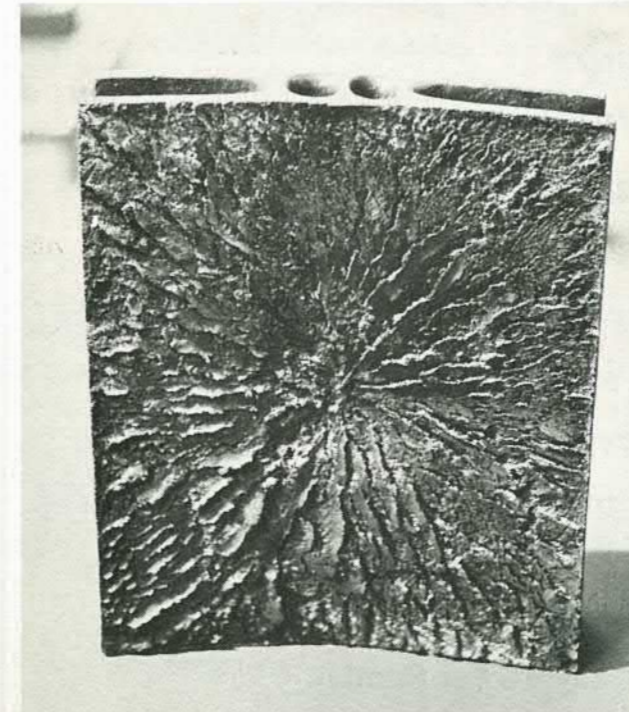
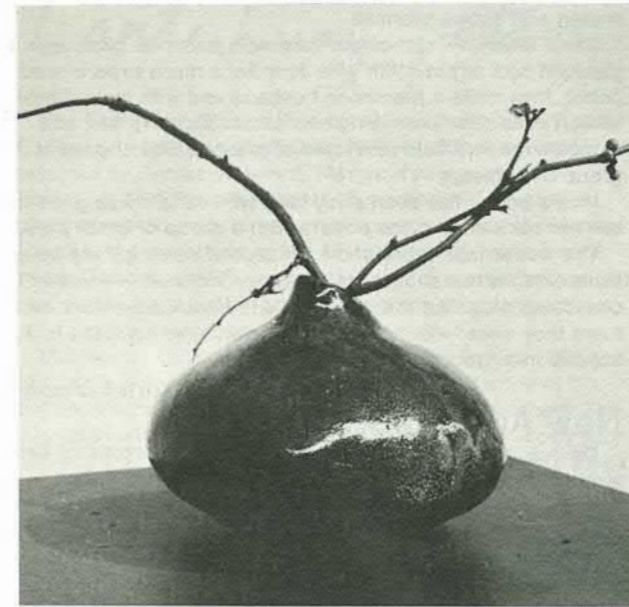
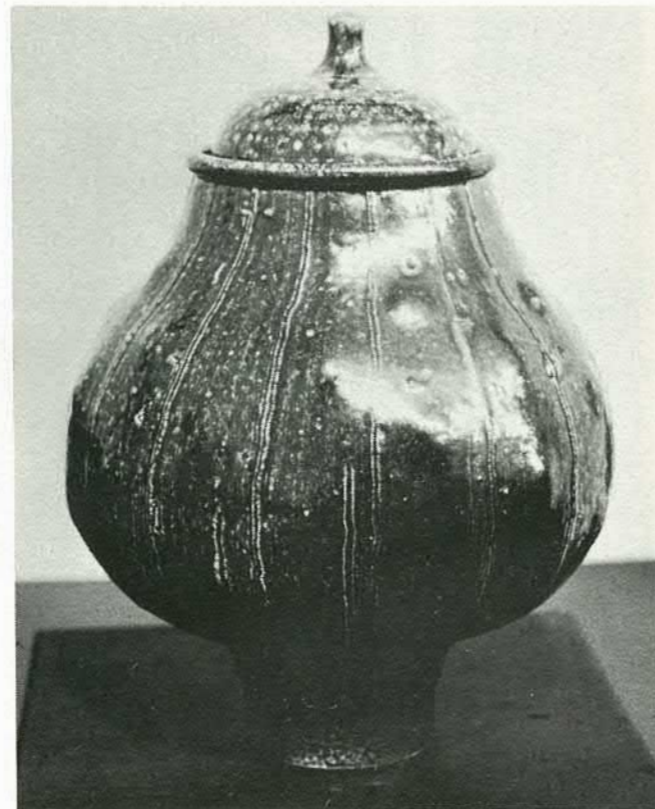

and platters and oblong dishes. These were more colourful than his work in the past and lacked some of the earlier glaze quality — probably due to a recent, if temporary, change from an oil burning to an electric kiln.

Roy Cowan also showed a number of large pressed bowls — some with high standing thrown bases. The shallow, concave shapes were used as a basis for bold stencilled decoration — not always successfully translated as a ceramic medium, particularly where strong black shapes dominated the surface.

Guy Mountain showed good colour in his oatmeal and ochre dinner set and a sense of humour in his "absurd Honey Pots", each standing on its own tall stem. I liked best his bowl, light and well thrown in a speckled, warm grey. It was marred only by unnecessary light brush strokes on an already beautiful interior. Jocelyn Mountain's work is big and bold and of joyful things — bells and fountains and candle holders.

Arnaud Barraud showed only three pots, all basically the same form, a generously swelling globular shape rising from a high narrow foot. Two of the pots were salted — one with a heavyish, ill-fitting and rather bubble-breasted lid — but the blue and white, carved, porcelain vase was one of the pots of the show for me.

Charles Holmes had some attractively coloured tiles and some strong, square, sculptural pieces, black and heavily textured with touches of gilt or selenium red. He also showed a collection of "fin pots", matt black, hand-formed cylinders with protruding, sharp-edged fins. These pieces could possibly be criticised for being harsh or metallic and unclaylike, but where other similar pots have sometimes failed these are, I think, successful because of this potter's sure sense of form.

John Fuller

opposite page: dry grass pot Margaret Symes and lidded jar Arnaud Barraud. On this page above: Japonica bottle Jocelyn Mountain, bowl Margaret Milne (bought by Palmerston North Teacher's College), Sculptural piece by Charles Holmes

photos: Stan Jenkins



# Wellington potters

The overall standard of work being done by Wellington potters is improving if judged by the pottery exhibited at their annual exhibition in Rothmans' Gallery in July.

The pots were displayed against a background of batik panels by guest artist Diana Dekker. As an artistic arrangement the display was successful, but from the point of view of seeing the pots to advantage, it was overcrowded. Perhaps an answer would have been to cut down on the number of pots.

The pot of the show was Juliet Peter's round branch pot with narrow neck and a blue-green glaze reminiscent of a giant poppy seed head. Anneke Borren had an outstanding stoneware lidded pot in subdued colour. All her things well deserved their place. Patti Meads' cylindrical ikebana pot and lamp base were notable for their good colour — oyster grey merging to black.

Flora Christeller showed a fine, big pot with a well matured tenmoku glaze. Raeburn Laird must be singled out as the most improved potter. Her several sets of high fired earthenware, show she has control of her medium. Arie van Dyk produced a large and lively bowl. Judith McMillan's jars and plate and pencil holder made an attractive group. She used Mexican motifs for decoration which shows that designs do not have to be original to be worthwhile. Audrey Brodie's bowl had a pleasant liquid glaze.

Ray Mudd exhibited a well made decorated flat inlaid pot. Dave Dalrymple had a fine thrown vase with sensitive decoration. Muriel Wright achieved interesting effects with rubbed on oxides on her hand-built stoneware platter. Jill Bagnall has a nice feeling for a small pot; her work is carefully

crafted and shows promise.

David Shearer's stoneware vase with tenmoku glaze was a pleasant sort of pot. With wife Jennifer a more experienced potter, they make a promising husband and wife team. Carol Wilson is another promising new potter showing flair and competence in a field restricted at present. She showed a group of bottles.

Minna Bondy has been away for a while and it was good to see her back among the potters with a group of small pots.

This was an interesting show. On second viewing there were some exhibits that should not have been included — some self conscious pots. Not that one wants to knock adventure, but there they were — contrived pieces that have no place in an exhibition of good pottery.

**Muriel Moody**

## New Auckland Gallery

On July 1 Auckland's new Alicat Gallery presented its first exhibition, the work of Andrew and Jean van der Putten.

Andrew has always had the reputation of being a "potter's potter" and the opening tended to underline this. Present were Len Castle, Jeff Scholes, Doris Dutch, Adrian Cotter, Richard Poor, Howard Williams, Charles Holmes and Don Thornley. And in the fortnight that followed almost every potter in an around Auckland must have come in to look at the pots.

Reviews of the exhibition were excellent which should add to the already considerable reputation of Andrew and Jean van der Putten.

**Peter Sinclair**

**PETER SINCLAIR'S**

## ALICAT

*New Zealand's newest gallery, bringing you  
the finest pots from the finest potters  
in the country.*

*Only a minute or two from the heart of Auckland,  
Alicat features a special window display  
from a top potter each month,  
a major exhibition every six weeks.*

*October: From breadcrocks to trinket boxes.  
An exhibition of very large to  
very small pots.*

**ALICAT GALLERY**  
**52 JERVOIS RD, PONSONBY, AUCKLAND: 769874**

**Open from 10 a.m. every day except Sunday**

# Canterbury potters

The Canterbury Potters Exhibition was held in the C.S.A. Gallery Christchurch 12-27 July 1974 — 162 pieces were selected by Denise Welsford, Margaret Higgs and Rex Valentine from the offerings of 45 members. The work in general was soundly based on precepts extolled by Bernard Leach and exemplified by the Mingei Pottery traditions of Japan. The standard this year was in my opinion better than last year and it was heartening that some of the strongest work was from younger members of the Association.

Michael Trumic displayed two magnificent bottles. However, Michael exerts such a strong influence that the top of his bottles reappeared on far, far too many bottles by others. The possible variations of form are practically infinite. Surely such duplication of a successful detail is at the least a sign of a lack of imagination.

Hiroe Swen's influence was also evident — again a pity that such a strong influence hadn't been more completely assimilated before work was exhibited. Lawrence Ewing displayed a very strong group of pots with carefully worked and scaled rope handles. Paul Fisher and Brian Cooke also showed good work.

In any exhibition, size, extreme form, daring colour or extravagant texture all draw attention. Frequently the very quiet pieces that carry more ultimate satisfaction are overlooked. Nora Flewollen's charming condiment set with immaculate glaze and delightful colour falls into this category. Rex Valentine's work is also sometimes overlooked yet his set of landscape plates and in particular his set of bowls with unusual oil spot tenmoku glaze were worthy of concentrated study.

The Association was honoured by having pieces by Denise Welsford, Gennie de Lange and David Brokenshire purchased by the MacDougall Art Gallery.

The use of carpet flowing up over platforms at various heights together with the contrast of muted colours gave a fine background for the exhibition.

**David Brokenshire**

*David Brokenshire himself exhibited four large primitive-type vessels called "missionary pots" (for small medium and tall missionaries). He also showed a sculptural form titled "evil wind" and a collection of small porcelain pieces with celadon glazes. (ed.)*

*photos: Nola Barron*

**Denise Welsford**



*Rex Valentine*

**Brian Cooke**

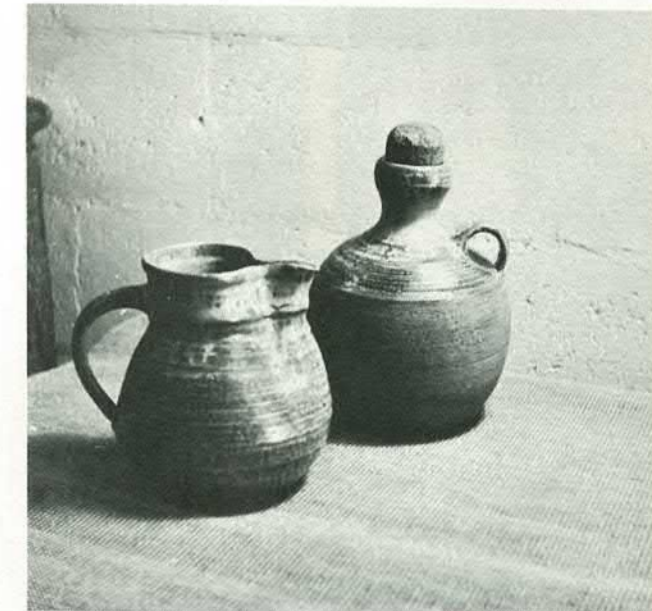

**Nora Flewollen**





# Academy

In Wellington in July the New Zealand Academy of Fine Arts held its annual exhibition of pottery sculpture and graphic art. This year guest potters were Juliet Peter, Yvonne Rust, Frederika Ernsten, Jim Greig and Peter Stichbury. The theme for the exhibition was "pots to use".

Juliet Peter displayed a branch pot, an 18 inch high plant box (illustrated), and three platters of the kind that we recognise as Juliet's own, for holding fruit or other food. The craftsmanship, as always, was of a high standard and everything was eminently usable.

Frederika Ernsten selected a bowl, a vase and two bottles of elegant form and fine finish. Peter Stichbury's offering showed his customary competence. His wine set and coffee set were simply and effectively decorated, but the angular decoration on one of the platters was dominant and at variance to its circular shape.

Jim Greig's unfolding growth forms were shown in the last issue of the Potter. Three big bowls from this series were displayed together with a set of asymmetrical tiles.

A vase, a massive candle holder, a sunflower wine pot and goblets and two fountains with pumps, came from the kiln of Yvonne Rust. A house with 3000 square feet of floor space in the open country is about the scale needed to make these pieces feel at home.

Among the notable pots from other exhibitors were a comfortable jug by Arie van Dyk, an iron glaze plate and a bud vase by Eric Stevens and a collection of stately bottles by Carol Wilson (illustrated). Her "landscape pots" were bottles with overlapping tones in the glaze. Patti Meads' forty four piece luncheon set in pale turquoise earthenware showed great control of technique. Anneke Borren's group of flowers in bright earthenware colours and her twelve piece centipede had to be noticed; they contributed some originality and gaiety to that corner of the exhibition.

M.M.H.

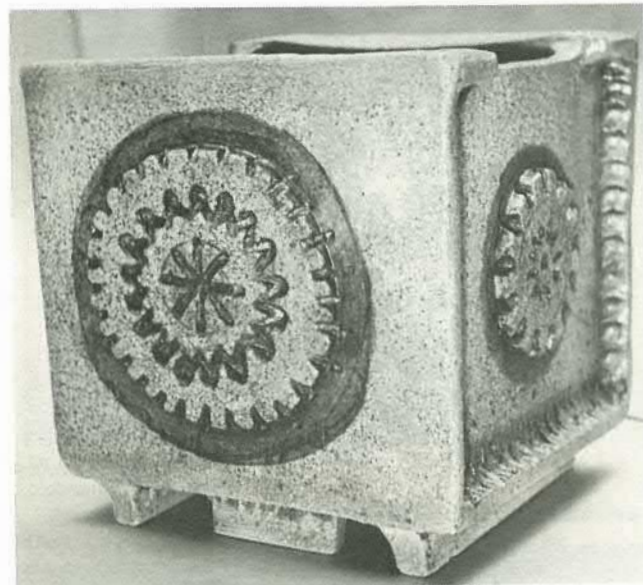

Juliet Peter plant box

Carol Wilson bottles photos: Terence Taylor

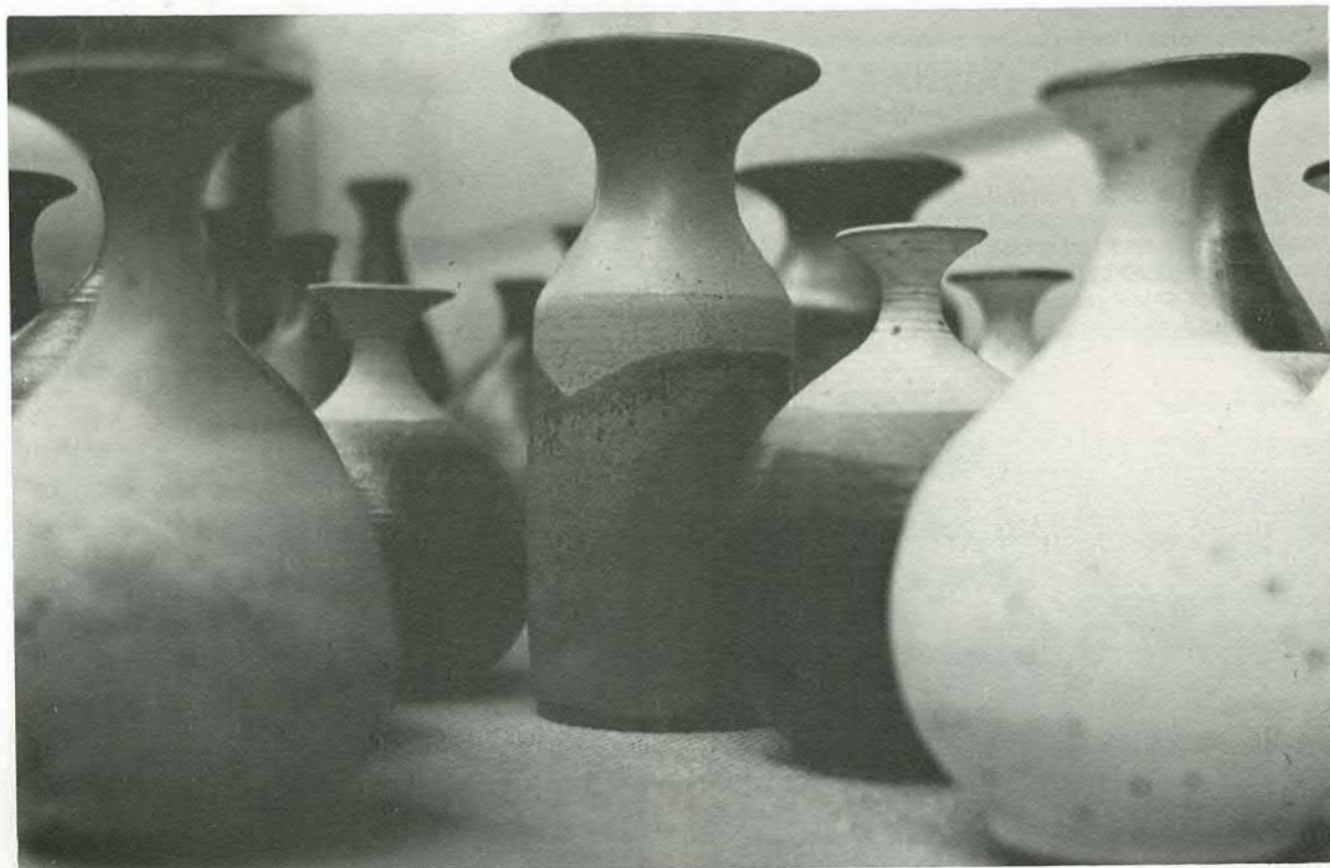

below: Brickell unglazed forest pots exhibited at Essex Emporium, Auckland

Right: Yvonne Rust's fountain exhibited at New Vision, Auckland. photos: Steve Rumsey.

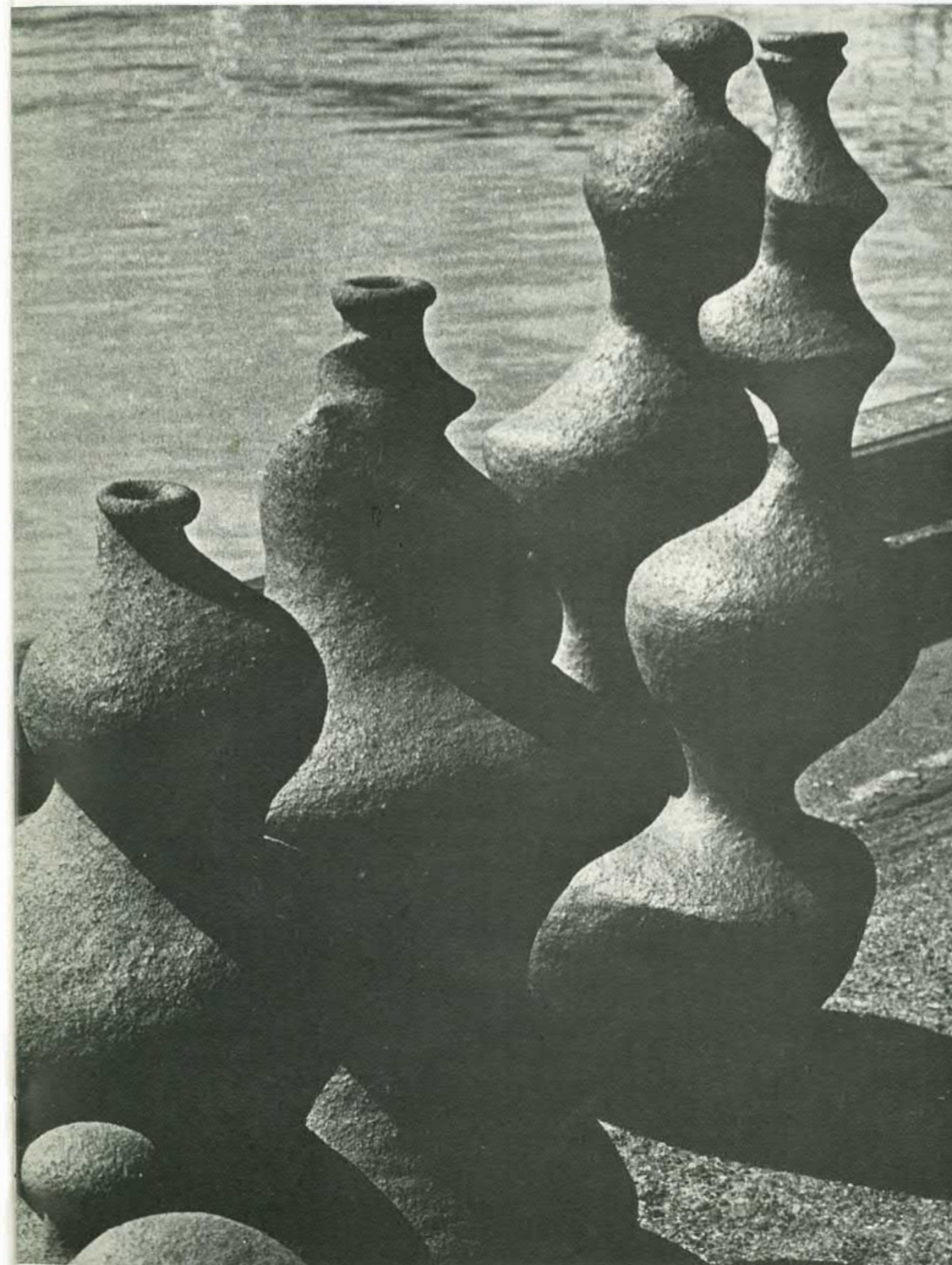





## OTAGO POLYTECHNIC

### FULL-TIME COURSE IN CERAMICS

Otago Polytechnic School of Fine & Applied Arts offers a one year course leading to a Certificate in Ceramics. Applications are invited for the 1975 course. Bursary assistance is available to qualified students who have not had previous assistance in tertiary education.

Enquiries to: Mr R.J. Dickison  
Course Supervisor  
School of Fine & Applied Arts  
Otago Polytechnic  
Private Bag  
DUNEDIN

### OTAGO POLYTECHNIC

#### CERAMICS TUTOR

A tutor-in-charge is required for the Ceramics Section of the School of Fine & Applied Arts. Applicants must be competent potters with teaching and administrative ability.

The School has the best facilities in New Zealand for Ceramics teaching and caters for full and part-time students. A one-year full-time course was started this year.

Salary : either Tutor 1 \$5084 to \$7557  
or Tutor 2 \$6934 to \$9225 Enquiries to : Deputy-Principal,  
Otago Polytechnic,  
Private Bag, Dunedin.

Pots for sale, plus a few prints and a painting or two Roy Cowan and Juliet Peter at the Settlement Gallery, 155 Willis St on Monday May 13th between 4 and 6.30 pm

The Settlement Gallery was bursting at the seams. Juliet and Roy's pottery is so usable that everyone wants to buy it. This was a small show of characteristic high quality work in an almost domestic setting with the prints taking equal place with the pots.

*pots outside*

M.M.H.

Outdoor pots need to be displayed in an outdoor setting and Essex Emporium in Dominion Road, Auckland, provided such a setting for an exhibition of garden pots by a dozen potters from Coromandel and Auckland. With the help of some potters Essex have converted a city backyard into a garden courtyard with mellow old bricks and rough, bark fence. Not all the pots were terra cotta. John Tolands' wood fired kiln produced two glazed stoneware pots; and Don Thornley exhibited stoneware blossom jars and tablets. Una Sharply displayed barbecue sets for tea, for curry and rice and for wine, all in glazed stoneware.

Barry Brickell's contributions were two glazed stoneware terrace pots, a sculptured fountain and a series of four foot high, unglazed forest pots. Brickell likes working on a big scale. The forest pots were generous forms with richly toasted surfaces showing rugged strength appropriate to use outdoors.

Other notable pots in this exhibition were Merle Bryildson's large bird pots and Claire Dockstader's huge unglazed acorn pot.

Auckland Star

#### Swap Jobs

Australian teacher/potter wants to swap jobs and houses for one year under the exchange scheme.

"I am a social studies teacher, Bachelor of Economics - teach economics geography and history in upper school.

I sell \$A4000 worth of pottery a year - stoneware fired at 1300°C in two chambered oil fired catenary arch kiln. Have well equipped workshop - 2 electric wheels, large capacity, pugmill, ball mill, 50' x 50' shed, clay preparation bed for local clay - Vanguard utility.

The near-new two storey house is on the beach at pleasant holiday resort of Brusselton Western Australia".

An interested New Zealand potter or suitably qualified social studies teacher could write to Erland Happ Box 410 Western Australia 6280

#### CREATION

*It has been pushed out from the womb of the earth,  
Born as molten rock in a labour of fire.  
Mother Earth has given birth to her child of granite.  
It lies on her breast, hardening, shaping.  
The birth pains are over,  
The orifice heals.*

*Water and wind nurture the child  
Until it divides  
Into smaller and smaller particles.  
With the care of the rain and the wind  
It ages. Then, dust to dust  
It becomes.*

*So it is washed to the gullies and lower places  
Where it lies, awaiting its rebirth,  
When a god will give it eternal life.  
One day he comes and gathers the clay  
Into his great, gentle hands.*

*Lovingly with water he embalms it,  
Kneads it, shapes it  
A form of beauty, rising and spinning  
On a wheel of  
new life.*

*It gleams with the water as it becomes  
A fluid, graceful form,  
Growing, expanding, lifting  
In plastic beauty.*

*And then to fire once more it must go.  
Fire the purifier and new life giver  
To emerge from this pyre  
Not charred and dead and blackened,  
But transfigured ...  
Alive and glowing  
With a beauty as never before.*

*Its rhythm glows with the life of the fire,  
The colours are those that have been hidden there.  
So this beautiful, glowing object  
Lives ... forever.*

W.A. Jewell

Queensland, Australia

#### Pottery in Australia

Published by the Potters' Society of Australia, twice yearly in spring and autumn. The yearly subscription is \$A3 and the magazine may be obtained from the editor Pottery in Australia 39 Mary Street, Longueville, Sydney 2066.



# Clay Preparation

by Jack Luckens

The preparation of clay has always been a potters heaviest and usually most arduous task, and for this reason many potters — I would venture to say *most* potters — buy their clay ready to use.

Nevertheless, for many reasons (recipes, coarseness or fineness) or like me just plain cussedness, some of us prepare our own, utilizing a local clay, perhaps mixed with others.

Clay, to be satisfactory should be a homogeneous mass of suitable consistency. For this reason some of the locally prepared bodies fall down as they are prepared with machinery used in the brick and pipe industry, with the result that the product is often not as well mixed as could be and contains undesirable pieces of wood, coal, road metal and even nails. The ideal method is what some potters call the "kindest" method — reduce dry clay to a slip, then get rid of surplus water and presto — clay.

Simple, in theory, but how frustrating in reality. The article and design of a filter press a couple of years ago in the "N.Z. Potter" shows the interest by potters in the subject, but a filter press, while ideal for continuous and large production, requires mechanical and engineering capabilities often beyond the average studio potter. I am therefore offering a method which is capable of use by even those of us not so robust, and to produce from 1 kilo to 200 kilos at a time — or from ½ gallon bucket to a bathtub full.

I have evolved this system over 10 years and while I would not claim it to be perfect, I think I have ironed out most of the bugs; each operator will find adaptations to suit his or her apparatus and ingenuity:

1. Dig and dry clay.
2. Break up clay — the finer, the quicker the slaking.
3. Slake clay and pour into container through sieve.
4. Add other ingredients — feldspar and other clays.
5. If possible sieve again into a second container, settle and decant several times stirring well after each decanting.
6. Ladle out into cloth and hang.
7. After several days take down puddings and flatten on concrete floor.
8. Place pancakes on wedging table, remove cloth and knock into suitable blocks to wrap in polythene and store.

An alternative to drying in cloths will be described which is faster and suitable for small lots of from ½ to 5 kilos, replacing operations 6, 7 and 8.

1. Thorough drying of clay prior to crushing is essential — it is easier to crush and slakes better, and therefore goes through sieve better.

2. Any containers can be used, but for a useful quantity of clay (200 kilos plus) old cast iron baths are the best for several reasons, and two are better than one. They are not too deep, which aids filling and emptying, if placed on two bars they may be rolled with the aid of a bar and hook, thus making decanting easy. They are cheap (scrap iron value \$2) as well as being robust, if there is no plug, fitting a couple of pieces of hardboard or plywood and a roofing bolt will block the outlet — a perfect seal is not needed.

Slaking — I use five four gallon square tins — Kerosene tins to us oldies — about ¾ full of water and put about 4 kilos of dry clay in each. Slaking time varies with clay. Stir with blunger and pour into bath through desired sieve. A 16 mesh sieve for a coarse body and a 20 mesh makes a nice fine body. Extra water may be needed for the first bucket or two, after that, surplus water on top of sieved clay in both can be used to wash clay through sieve. A high pressure hose may also be used for washing clay through sieve. I grind my dry clay to about 16 mesh in a grit grinder, and find that to sieve 20 kilos only takes 6-7 minutes. Keep a check board with chalk to record what you put into the bath. My normal mix is 140-150 kilos dry weight of all body ingredients (except grog) which makes around 200 kilos of plastic clay. If using powdered clay (Hyde ball, airfloated fireclay) and feldspar or talc in the body, leave these till all washed clays are in. If the bath is too full, decant after settling awhile. It is a characteristic of airfloated clays and feldspar not to settle readily, whereas washed clays unless of bentonitic or other very fine types usually settle quickly.

Now add the powdered clays and they will settle into the surplus water on top of the bath, though it may take a few minutes after spreading each bucketfull. It is useful to use a coarse sieve to spread these powders (and to remove string and other impurities).

Once all the ingredients are in the bath, then stir thoroughly: a 4" x 3" piece of wood or ply nailed into the end of a stick is ideal.

Ideally it is now better to bucket the contents of one bath into another through the same sieve, first it makes sure that there are no pockets of one variety of clay left, secondly it aids greatly in the mixing and thirdly it removes any debris such as blown leaves and twigs that get into the first bath, as it takes two or three hours to complete the first process.

Now get a 6 foot sheet of corrugated iron and place over the bath. This keeps out further leaves but not all the rain, but that matters not for the clay may now settle. One may start to dry out the clay at this stage, but it is better clay and has less water to get rid of if left for several days or even weeks. One point — decant after 24-48 hours and stir thoroughly again — levitation in the wetter slip will tend to place a noticeably coarser fraction to the bottom and the finer to the top; this also has the effect of trapping water. If water is decanted and *not* stirred, less water will rise in the next 24 hours than if the slip is stirred.

Now for the really easy part of the job and the one which has in the past been one of much frustration. All open drying methods have problems of uneven drying and the danger of foreign bodies entering the slip including mice, bugs etc.

For several years I used newspaper as an absorbent for surplus water and indeed for small amounts — usually test batches, I still do. It has the advantage of speed and very even drying, but takes more time than the cloth method, and in large amounts presents a problem with used wet paper, and is heavier work. But it is still a good method and is as follows:

Procure at least two 18" by 24" sheets of hardboard, fibrolite or even plywood. On one place a good level wad of newspaper — a Saturday edition is about right. Ladle out as much slip as possible onto this; the quantity will depend on how long the slip has settled and therefore how thick it is. I get up to 15 lb of usable clay if the slip is really thick and only about 5-6 lb if it is thin.

Over this clay place another wad of paper, then a second batt to hold it down. It is better to use a single sheet of paper under and over the slip at first, as it may be peeled off more readily when the wad is removed. After a couple of hours remove the batt, then the paper. Replace with dry paper then a batt, then flip the lot over and do the same with the under lot, which is now uppermost. Always keep paper on top of the clay; oddly it never dries out at the edges and in fact the centre is usually slightly firmer because of contact with the paper. This method has a fair amount of elasticity. For instance the second paper may be left for a couple of days but will really be enough to absorb sufficient moisture. At the later stages the fibrolite may be used without paper, once the clay is past the sticky stage.

A better method if used with discretion is the cloth wrapping method. For this we need a number of squares of cloth a yard or metre square — 45" would not be too big, a convenient rail with either hooks or 4" nails about 3" from the ground, as many loops of light rope as squares — clothesline rope is a bit thick — ideally a synthetic up to ½" diam. is best. About 18" is tied into a loop. Synthetic material is better than cotton, which is rapidly affected by acids in the slip.

Place the cloth over a large basin 18"-20" diameter and not too deep; ladle slip into cloth (experience will soon tell how many ladels-full are required) gather up the corners, pass the loop round and interloop then hang on rail. Depending on thickness of slip and weather, drying time will vary, but 3 days is the shortest I have had. Rain does not affect drying appreciably, so any place will do, but a

preferable site is on the dry side of hedge or building. Direct sun dries the neck out though a hosing down will cure this.

When the bag feels just a little too soft for working, remove it from the rail and drop on to concrete to flatten it, making sure the loop fastening is still intact. Do the same with second bag then invert over first one, or if you have only one, invert it. This ensures the creases around neck do not dry more than the body.

Twenty four hours on dry concrete is usually enough; the constitution of the body and texture of the cloth all affect judgment of the internal condition.

Place the bag (now a flattish pancake) on wedging table, remove loop and open out. If too soft, carefully replace loop and put the bag back again on to concrete. Concrete seems to have an osmotic effect and sucks water out quite rapidly.

A yard square of cloth will take 10 kilos of clay — a useful lump to belt into a block and wrap in polythene. 10 to 12 kilos may be wrapped in 36" x 32" polythene and keeps as well as in a bag and is easier to wrap and unwrap. This also gives us the reason for using squares of cloth instead of bags. They are easier to load and unload, there are fewer problems in cleaning and they store more readily. They are as well cheaper and easier to make with no sewing involved. They are just a little more difficult to loop up, but so much quicker to load and empty, with the advantage that it is easier to prevent over-drying round the neck. I can hang up and fill 8 squares in 20 minutes and it takes just slightly longer to unload and block and wrap — 160-170 lbs of clay!

Well maybe you'll still prefer to go to the pottery supplier and buy it ready made — but good luck in either case!

## Cobcraft — Pottery Equipment

POWER WHEELS  
KICK WHEELS  
BENCH WHIRLERS  
TURNING TOOLS

Our range is being constantly added to

Full details from our distributors, Smith and Smith Ltd.

or COBCRAFT: Lamb and Son, Engineers  
94 King St., Rangiora  
North Canterbury.  
Phone 7379



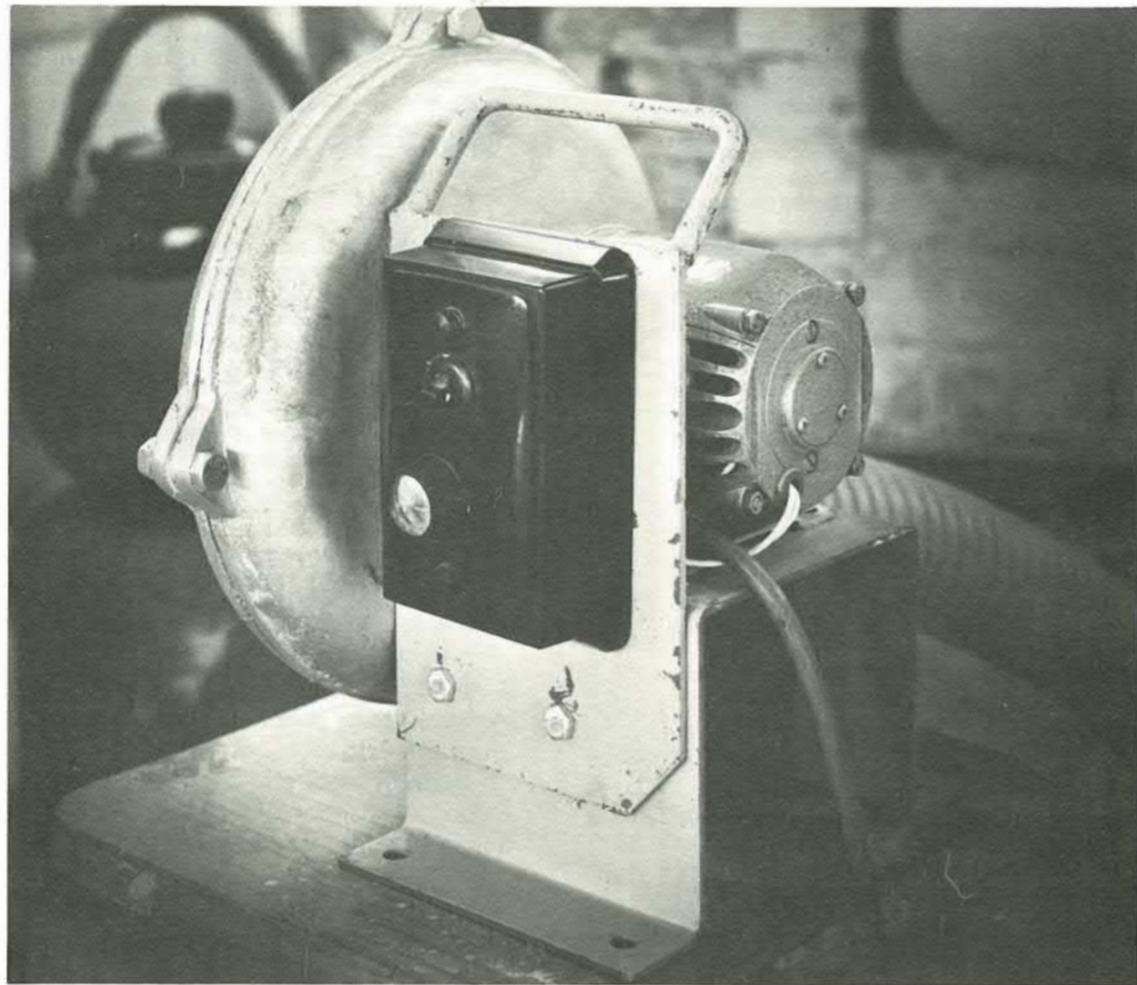

## RYLAND POTTERY KILN BLOWER

- ★ Tested on many high firing oil fuel stoneware kilns.
- ★ Simple variable speed adjustment provides accurate, controllable air flow at 3½ inches or more pressure.
- ★ Electric motor suitable continuous operation.
- ★ Connects to standard household three pin power outlet.
- ★ Compact in size - measures 11" x 11" x 11"
- ★ Easy to handle - weighs 19 lb.

Manufactured by

**TAYLORS LTD.**

Heating and Ventilation Engineers  
32 Lichfield St., P.O. Box 191, Phone 62-849  
Christchurch

Branches Auckland: P.O. Box 9599  
Newmarket.  
Phone 544-108  
Wellington: P.O. Box 30-663 Lower  
Hutt. Phone 698-745  
Timaru: P.O. Box 99, Phone 5159

### Mistaken identity

The pot on the left which we attributed to Margaret Milne in the last Potter was by Patricia Perrin. It was exhibited at the National Exhibition in Dunedin last year. On the right, fissured pot by Margaret Milne exhibited at the Manawatu Art Gallery this year.

photos: Stan Jenkins

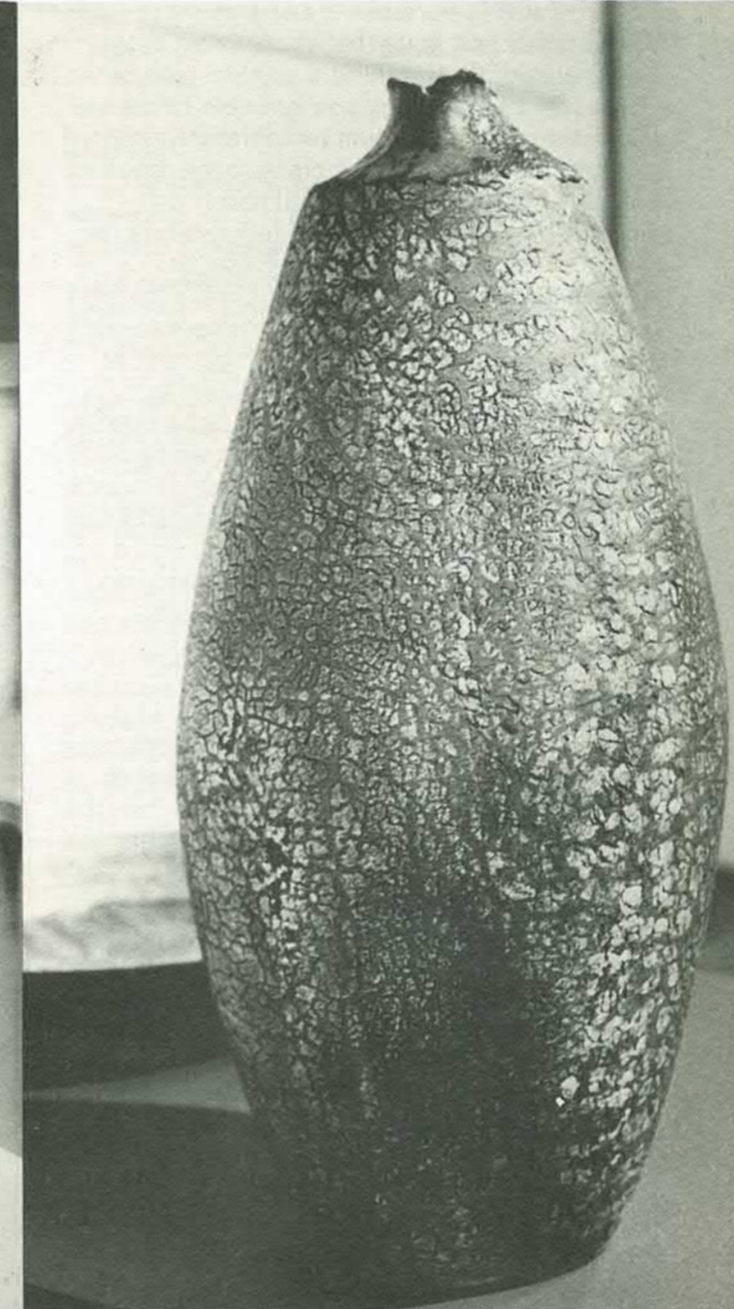
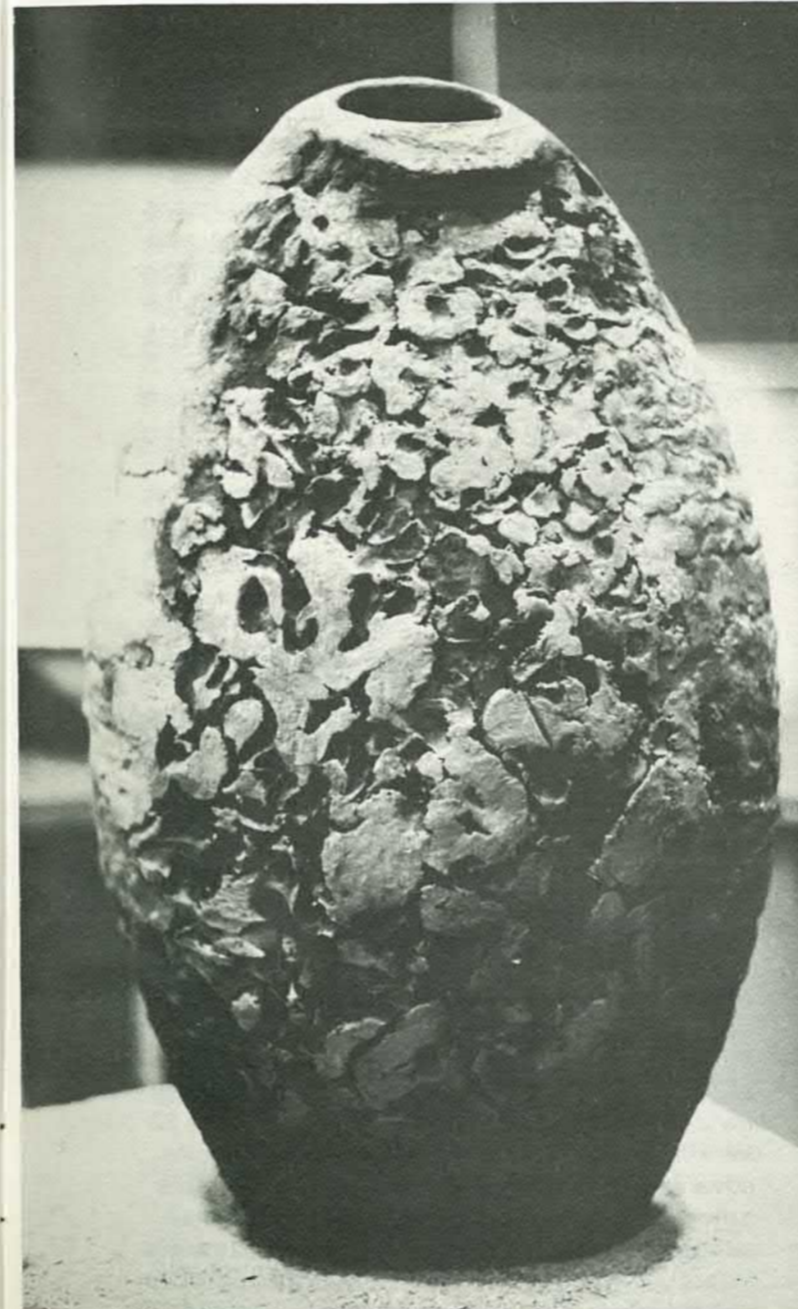



# ELECTRIC KILNS FOR STONWARE FIRINGS.

by Wilf Wright

The advantages of firing with electricity are the simplicity of the procedures involved. The fact that the kilns, especially the smaller average sizes are relatively portable, and that no chimney is required since no organic fuels are being consumed, contribute to their popularity as these are advantages that make for easy installation and kilns that are safe to operate in most home situations.

Not only are the normal procedures simple enough, but it is possible to become more sophisticated and have the whole firing cycle computerised. By installing a control pyrometer coupled to a timer clock you are able to set the pyrometer to the maximum temperature required and at the same time set the clock to the required soaking period and the kiln will reach that temperature and maintain that temperature for whatever time the clock has been set to.

One disadvantage with electric kilns is the high cost of the kilns in relation to the inside stackable space. And of course there's the high cost of installation. This is not such a problem for someone for whom pottery is only a hobby and is satisfied with a two cubic foot kiln costing \$300. But for the professional potter who may require a ten cubic foot kiln, the cost will be around \$1800 to \$2000. Naturally a potter considering such a purchase would want to be sure that such an investment would be economically viable.

## Installation costs

One of the most important considerations apart from the actual cost of the kiln is the cost of installation. Most of this cost has to be met by the purchaser and can only be determined after consultation with an electrician and a representative from the local power board.

When contemplating the purchase of a large kiln the first essential is to get all the relevant details from the manufacturer that will be needed by your electrician before he can work out the cost of installation. Once the electrician has determined what is required, the power board should then be asked for advice. Then a written quotation can be obtained from your electrician.

The power board is responsible for ensuring that sufficient power is available at your nearest pole, and from there the costs are yours. That is, you are responsible for upgrading the wires to your switchboard from the outside power pole and

any upgrading or replacement of the actual switchboard itself, and of course the wires from the switchboard to the kiln.

All large electric kilns require three-phase wiring which may consist of four aerials, one for each phase and one neutral. It can be in the form of one large cable with all four wires encased in a thick, plastic coating which can be used overhead, or placed to power board specifications in a two foot deep trench.

## Running costs

When discussing installation requirements with your power board it would be advisable to find out what your kiln will cost to operate. Consider the advantages of day and night metering. With most power boards cheap power is available for commercial ratings between the hours of 9.30 p.m. and 6.30 a.m. and the difference in rates is considerable. If you are a professional potter and using a large electric kiln you will automatically be put on to commercial rates for your power at the cost (in Reikorangi) of 3.1 cents per unit used. If you are on a night rating system between the hours of 9.30 p.m. and 6.30 a.m. the cost of power used is calculated at 1 cent per unit. Before you can be placed on such a system you must undertake to use no less than \$50 of power at the night rate per year. The average professional potter would use considerably more power than this in a year.

To be put on this system you have to have day and night meters and a timer clock relay mechanism added to your switchboard. The power board will supply the meters and the clock, but if your switchboard is not big enough to take them you have to pay your electrician to put in a larger one or make a small panel to be placed alongside the existing switchboard.

For stoneware firings the firing cycle exceeds the night rate period, but the change over from the day meter to the night meter is automatic. The following information may be a help in assessing operating costs. At Reikorangi we operate two seven cubic foot kilns with a rating of 19 kw over three phases and a ten cubic foot kiln with a rating of 32 kw over three phases. This means that the 19 kw kilns use 19 units of power an hour and the 32 kw kiln uses 32 units. The table shows definite advantages in using the night rates. (Since this article was written it has been discovered that although the 10 cubic foot kiln is rated at 32 kw it is in fact using no more than 24 kw over three phases and therefore is using 24 units of power an hour. I

kW rating	Type of firing	Max temp	Time taken for firing cycle	Hours on day rate	Hours on night rate	No units used day rate	No units used night rate	Cost of day rate	Cost of night rate	Total cost
32kW	glaze	1300	13hrs	4 hrs	9hrs	128	288	\$3.84	\$2.88	\$6.72
32kW	glaze	1300	13hrs	4hrs	—	416	—	\$12.48	—	\$12.48
19kW	biscuit	800	7hrs	—	7hrs	—	133	—	\$1.33	\$1.33
19kW	biscuit	800	7hrs	—	—	133	—	—	—	\$3.99
24kW	glaze	1300	13hrs	4hrs	9hrs	96	216	\$2.88	\$2.16	\$5.04
24kW	glaze	1300	13hrs	13hrs	—	312	—	\$9.36	—	\$9.36

have included in the table figures to this effect.)

It is interesting to note that the night rate system was originally worked out for bakeries and was known as the "bakers' rate". As we glaze fire in the 32 kw kiln and biscuit fire in the 19 kw kilns at the moment, the figures quoted show our present firing pattern.

The number of units used by each firing cycle is actually slightly less than those quoted. This is because in the early stages of the glaze firing the rate of increase in the temperature is kept down. This is done by turning the simmerstat control to a low setting which in turn activates what is called a contactor which is a magnetically operated make and break circuit control instrument. In this way all elements are always on simultaneously when the simmerstat is on high, while at lower settings the elements are all on for a set duration, and all off to a set duration, relative to whatever the simmerstat dial is set to. This means that in the early stages of the firing there is a total duration of time in which no power is being consumed. In the interests of simple arithmetic I assessed the costs of the day rate units at 3 cents a unit instead of 3.1

On the basis of the costs shown in the table, there is no doubt that electricity is a reasonably economic fuel especially if you make use of the night rating. And if one wants to be altruistic, there is a reduced demand for power in the community at night and therefore if a potter does most of his firings at night he helps to spread the demand.

## Maintenance costs

As any potter knows, the fuel costs are not the only cost involved in firing a kiln and with an electric kiln the replacement of elements are the other big costs. Basically there are three types of

elements:

(a) elements wound from a patented alloy known as "Nichrome" wire with a maximum working temperature of 1200c

(b) elements wound from a patented alloy known as "Kanthal" wire with a maximum working temperature of 1300c.

(c) elements which take the form of rods made of silicon carbide with a maximum working temperature of 1400c to 1500c.

Obviously for stoneware potters the silicon carbide rods would seem to be the most satisfactory. Unfortunately the cost of these, for even a very small kiln, is prohibitive and apparently they can still be burnt out at any time and are expensive to replace.

Nichrome wire is the standard wire used for radiators, toasters and so on and even in a heavy grade is not suitable for use in a kiln to stoneware temperatures, or even for sustained use to earthenware temperatures.

Kanthal Al is much more satisfactory. Most manufacturers use only Kanthal Al wire for elements.

Most kilns are made in such a way that they consist of an inner chamber lining of light weight refractory bricks with insulating bricks or insulating material of a loose nature between the inner lining and the outside steel case. Many manufacturers prefer to set the elements in grooves cut into the bricks making up the inner lining. At high temperatures, the elements do tend to crawl out of the grooves. This may be remedied by heating the element that has moved, with a gas torch until it is red hot and slowly bending it back into place again.

Another method of setting in the elements is with a series of individual ceramic tiles designed



in such a way that the elements are held in position. Each individual tile can be replaced This is a much more expensive method However.

Earthenware potters firing their kilns at temperatures ranging from 1050c to 1150c do not have the problems that stoneware potters have with element loss. When firing stoneware, the maximum temperature reached may be close to 1300c which is near the limit of the Kanthal Al wire. But if care is taken not to exceed the maximum working temperature then element loss should not adversely affect the economic viability of stoneware firings.

It's always a good policy to discuss fully with the manufacturers the maintenance procedures and general management techniques of the particular kiln concerned.

**Other costs**

Freight charges on a large kiln weighing anything from one to two tons can be considerable especially when a fork lift crane has to be hired.

Another cost not already mentioned is shelves. Suitable shelves of high quality silicon carbide required for the higher temperature firings are available at prices ranging from \$7 for a 12 inch by 8 inch, to \$20 for a 20 by 20. Supports of the same material are available at prices ranging from 22 cents each for a one inch prop to 54 cents each for a ten inch one. These prices are likely to vary from

one shipment to another.

**Glazes**

It's best for potters to work out their own glazes for electric kilns to suit their own needs. Most standard iron glazes (tenmokus etc.) with a maturing range between 1250c to 1300c fire well in electric kilns. Papa glazes give good results and experiments using papa with whitening or ash in amounts from 10% — 20% should produce worthwhile results.

Celadons are also possible, although the results are not the beautiful cool blue type typical of reduction firing in either oil or wood fired kilns, but tend to be more a warm yellow green, quite interesting in its own way. Magnesium glazes respond well in a neutral or oxidising firing and some interesting combinations of matte glazes and iron washes over textured surfaces are possible.

We still use oil fired kilns at Reikorangi. We always look forward to firing a kiln where we are dealing directly with the basic element of fire and the results that can be achieved by reduction.

However we have found that it is possible to produce interesting pots from electric kiln firings at stoneware temperatures: that electricity is not an expensive fuel: and that because it is most convenient, more regular firings are possible and consequently a more regular income is obtainable.

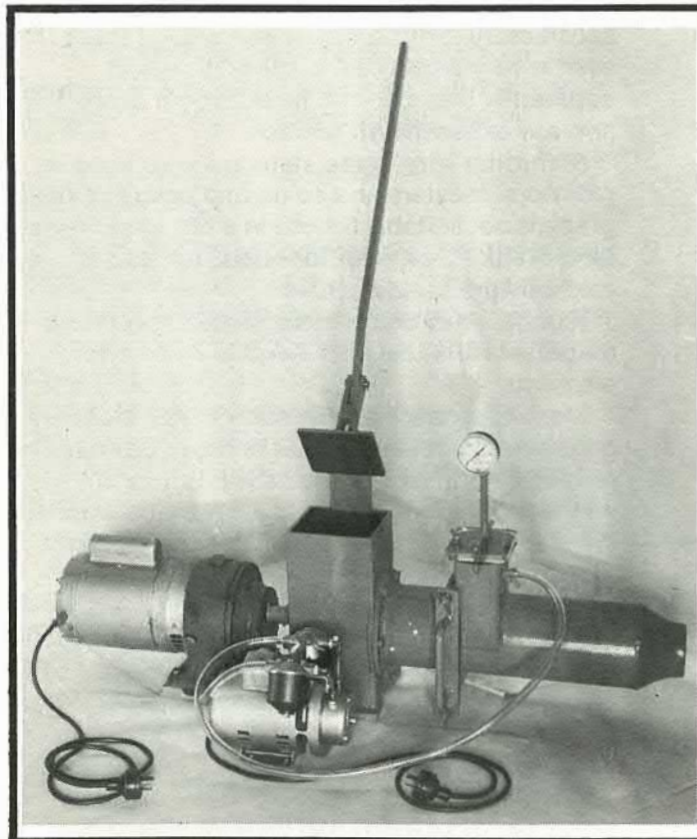

Capacity 6 cwt per hour  
 3/4 Horse power single  
 phase motor with overload  
 protection. Complete ready  
 for use.

Price: \$852.00 ex works  
 P.O. Box 51-032, Auckland  
 phone 596-603

**CODES MARK 4 PUG-MILL**

**NATURE AS DESIGNER**

**Bertel Bager — Frederick Warne London 1967**

Dr Bertel Bager, distinguished Swedish surgeon shares with us a lifetime of study of the design of plant forms, in particular those of seed capsules, the beginning of life in which nature seems at its most inventive. The magnificent record made by his talented photographic friends of the great variety of organic forms will be a source of inspiration for potters whose work derives from these. While the photographs and texts are excellent in themselves they should stimulate personal research into the great variety of our own indigenous forms both of land and sea.

This is not just a coffee table book but as much a text book as Daniel Rhodes.

My copy came from Black of Cambridge U.K. but I have seen one in Vital Books, P.O. Box 8601 Symonds St., Auckland, if your local supplier has none.

**Olaf John**

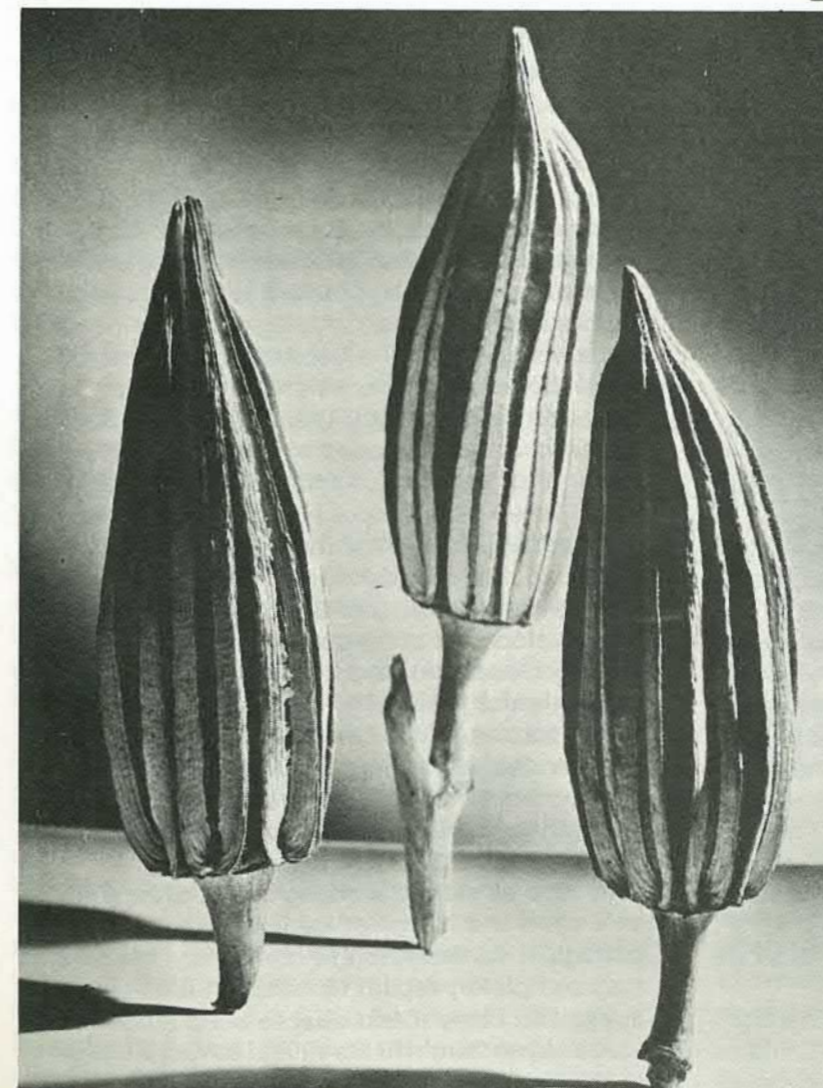
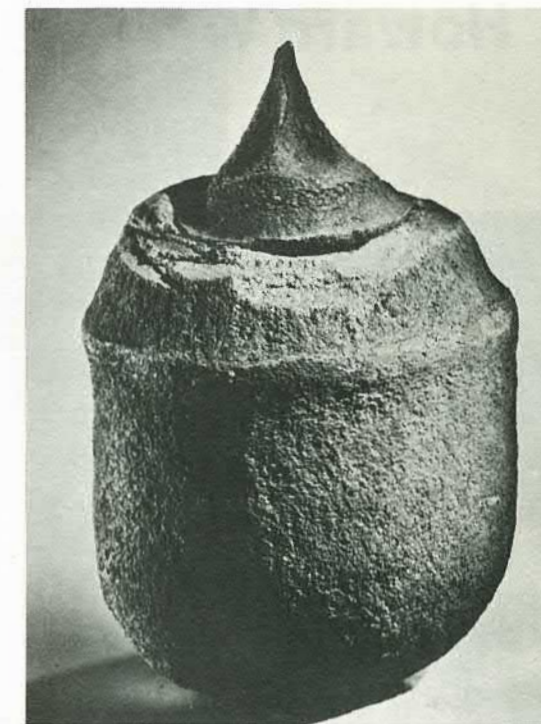

Above: *Lecythis Pisonis*  
 Left: *Hibiscus Esculentus*



## Howard Williams - Ceramic decorator

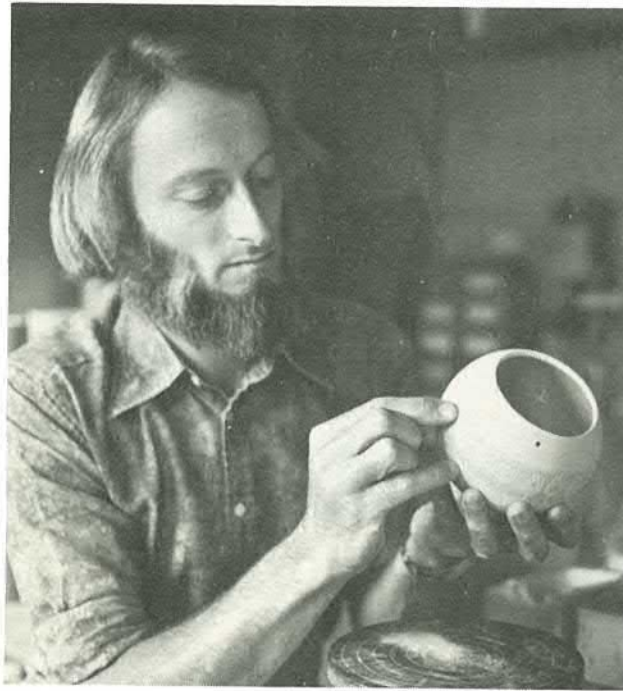

Howard Williams is primarily a decorator. He uses the slip casting technique to provide earthenware ceramic forms for his decoration. His is the graphic artist's approach to ceramics, and this is new in this country with its established tradition of high fired stoneware where the emphasis is on form. A piece of decorated earthenware which owes everything to the skill of the maker and nothing to the effect of the fire is the antithesis of the pot from the raku maker.

Howard Williams learnt his craft in Europe, from an expert — Kenneth Clark. "Most of what I've learnt in the ceramic field was given to me by Kenneth Clark and his wife Anne. As well as giving me a job in the pottery he was a great teacher. Work often stopped when some practical problem arose, and the staff would have a discussion about it, or Kenneth would give us a full lecture on the particular topic. He was always ready to share knowledge. Anne was the decorator and I learnt from her by watching and listening".

Kenneth Clark at this time wrote his second book for Studio Vista, called "Throwing for Beginners". Howard took most of the photographs to illustrate this work.

With New Zealand landscape painter Charles Blomfield for a great-grandfather, Howard Williams was following a family tradition when he decided to

make a career in the arts. In 1956 he was awarded a third year specialist course at Dunedin Teachers' College where he made his first pot and fired his first kiln — a small electric one. As itinerant art specialist based in Hamilton he was still mainly interested in painting, drawing and photography and his first exhibition of drawings was in a Hamilton coffee shop alongside early Graeme Storm pots.

With Graeme Storm he spent the next two years travelling in Europe. It was here that his interest in pottery took root. He answered an advertisement for a decorator at the Sevier Pottery in Hampstead. To his amazement after an afternoon's practical test, he was given the job, the first time he had attempted to decorate a pot. Two years of fairly heavy slog followed, though he was learning all the time. From 9.30 am to 6 pm for \$12 a week he decorated majolica ware.

"The pots, mainly mugs, plates, cups and saucers and ashtrays, were thrown by Bill, a craftsman who had spent his life in a factory doing piece-work, throwing stoneware inkwells, bottles and acid jars. A girl pulled and attached the handles. Bill's son did the firing and the glazing. The decorating was done by another girl and by me. Mrs Sevier threw the Art Pieces and her husband managed the business and did all the selling. The decorating consisted of brushing coloured glazes and pigments on to a predetermined pattern. The earthenware pot was biscuit fired, then dipped in white tin glaze. The decoration was applied and then the pot was glaze fired. Three 6 cubic foot electric kilns were being fired continually in rotation".

During this period Howard met Kenneth Clark who became his teacher and the main influence in the development of his own work. When the Sevier Pottery closed, Howard went to work in Kenneth's pottery which was then in an ancient Clipstone Street stables. It has since moved to the Covent Garden area. He worked on Kenneth's staff for five years, mould making, slip casting, glazing and decorating, packing and delivery, doing murals and mosaics, some throwing and designing.

In 1968 he started working on his own. With his wife Lynn and daughter Keri, he moved to a 1680 cottage in Northampton which with Lynn's parents they completely rebuilt by hand. "It took six years living with cement and dust to build a house and studio. Lynn taught in the village school while I tried to develop my own style of pottery and market my

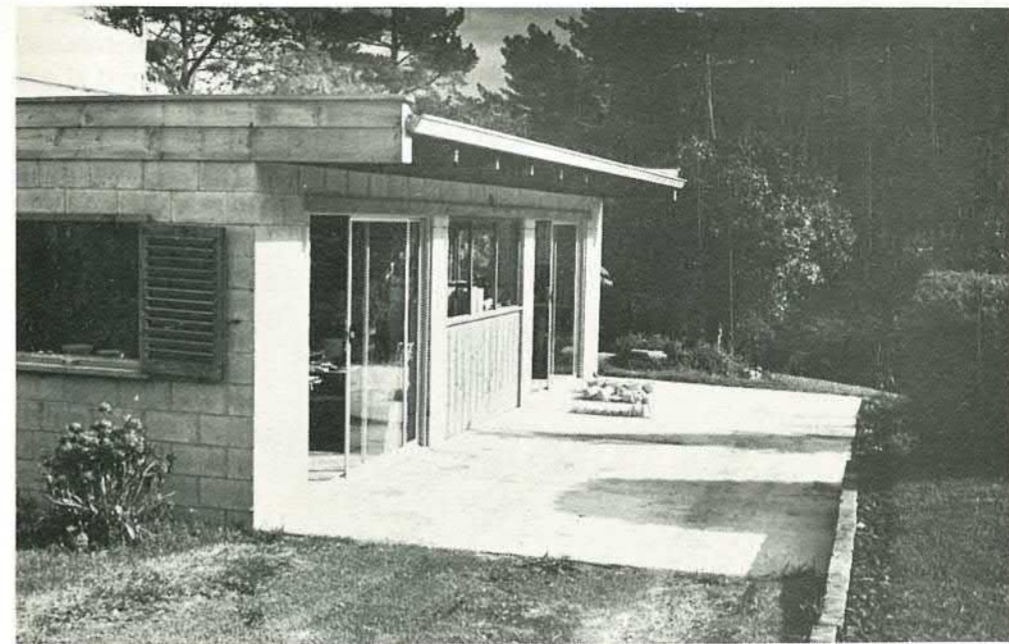

Left: Studio at Silverdale Auckland  
Below: Platter.

work. For a year we travelled to London every week to sell pots, my drawings and Lynn's embroidery at the open-air art market in Piccadilly's Green Park. We held several exhibitions of paintings, pots and jewellery at the studio and I had a one-man show at Alnwick, Northumberland. I was commissioned to make three ceramic murals in Northampton and a panel for John Dankworth and Cleo Laine's Wavendon Music School. In spare time we took the opportunity to visit galleries and potters like Lucie Rie, Hans Coper, Bill and Vicki Read and Barbara Cass".

In 1971 the Williams decided to come back to New Zealand. On a ten acre block at Silverdale 20 miles north of Auckland they established a home and built a studio. From Karanga Ceramics Studio Howard does his slip casting, tile decorating and mural panels.

He was guest exhibitor at the New Zealand National exhibition at Dunedin last year. This year he was invited to exhibit at the Manawatu Art Gallery. He has had one-man shows in Auckland, and Wellington people had a chance to see his work at Van Helden's Arts and Crafts at Day's Bay in June.

He has just completed writing his book, "Basic Pottery for New Zealand Conditions" which will be published by Beaux Arts at the end of the year.

"I was excited to return to this country as there is a great interest in craft work, particularly pottery, though I was at first worried by how my type of decorative work would be received here. Pottery in New Zealand has been largely influenced by the Leach tradition, and the scene seems to favour thrown stoneware fired in a home-built kiln with individually developed clays and glazes. Would slip-cast decorative earthenware, with raw glazes



sprayed on and once fired in an electric kiln be acceptable? Barry Brickell once called them "sophisticated damned things!" However, potters' interests in the whole ceramic world is so great, that I feel I can contribute a little in my own way from my experience in Britain. I think it valid to consider myself as a ceramist more than a potter and continue to cast simple shapes with smooth surfaces as vehicles for decorative techniques. The



important thing with a creative desire is to be true to one's own individual style and to the materials used, and to always have a deep concern for the quality of one's craftsmanship".

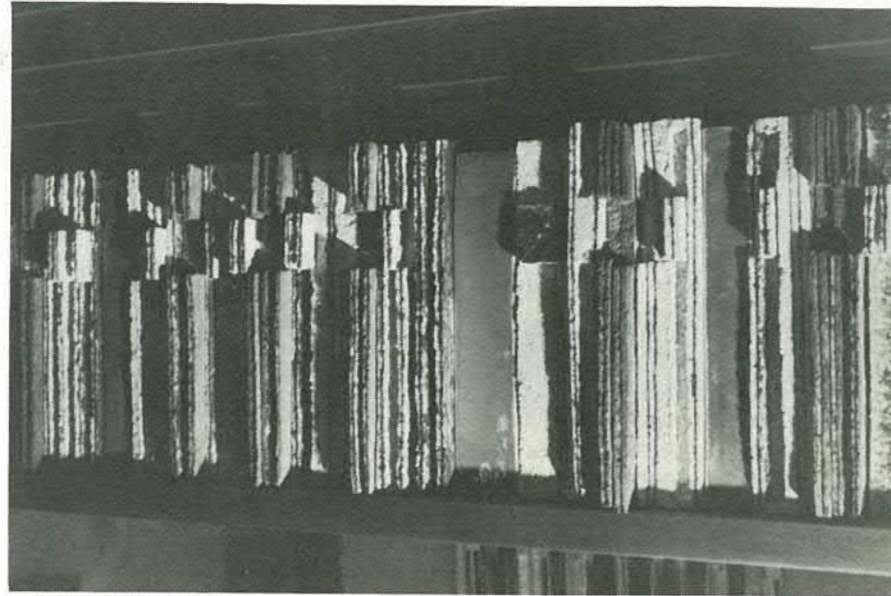

Mural for Auckland architect's office. Red and grogged buff clay with copper oxide, and strips with Cadmium/Selenium orange glaze 14" high 15 feet long. Photos: Howard Williams and Brian Wilson.

PETER SINCLAIR'S

## COUNTRY ARTS

*Only a short drive from the centre of Auckland, midway between bush and surf,*

*Country Arts has established itself as the home of a tremendous range of good pots.*

*We offer everything from the potter's wheel – large and small, rugged and delicate.*

*A special feature is our courtyard display of terrace and patio pots*

*along with a selection of plants to go in them.*

**OPEN SEVEN DAYS A WEEK AT MURIWAI BEACH, JUST OUTSIDE AUCKLAND.**

**Phone 69R Waimauku.**

**John and Ann Lawrence** have moved to Dannevirke, Hawke's Bay. John Lawrence says the kiln is bigger than before to take the new size English shelves. They intend firing two chambers of bisque and two chambers of glost to combat the rising cost of fuel. The Lawrences conduct courses, and pottery groups wanting information could write to them c/- 31 King Street, Dannevirke.

**Paul Melser** has moved from Featherston in the Wairarapa to Masterton. **Anna Gandy** who worked with Paul has taken over his old place in Featherston where a leather-worker and a furniture maker are also in production. On the day we called she was firing a heaving three chambered kiln more or less single handed.

May Davis in a newsletter from Peru said that she was going to England in July taking a break from pottery undertaking in Peru. She wants to visit her mother and restore her own health after a good stint of hard work in a difficult climate. She says "I hope Nina will to some extent take my place. I do not know how long it will be before I return. It depends on many factors, things here, and how I feel when I can see it all a bit less subjectively. Mr address will be 156 East Barnet Road, Barnet, Hertfordshire".

**John Parker** is still researching into oxidised stoneware in both electric and gas kilns at the Royal College of Art, London. "I have been seduced, not unwillingly I might add, by the delights of lustres, enamels, transfers, Egyptian paste and other low fired delicacies."

### Ted Twiss

In June the death occurred of Ted Twiss, one of Auckland's early studio potters, leaving a place that will be hard to fill.

He inherited from the Twiss family tradition a large share of that driving force which has kept them always busy and always seeking something new to do. With his wife Kay, he established a cooperative way of life in which the two shared their talents and worked together successfully making, selling or giving away beautiful and useful hand made articles.

On committees Ted was active and constructive, but as a background man he was a dependable tower of strength, almost indispensable for setting up exhibitions and always on hand for local functions whatever they might be.

He built a number of small kilns and advised in the operation of others. But to generations of potters the burners bearing his name have been a great contribution to firing technique. Twiss burners can be found in kilns throughout the country.

He made few pots but exhibited with originality in both local Auckland and National Exhibitions. He was a member of the New Zealand Society of Potters.

His wife Kay, and sculptor son Greer both carry on the creative family tradition. To them we extend our sympathy.  
Brian Lusk

### Correction

There was a printer's error in the title of an article in the last issue of the Potter. The Dowse Art gallery of course is the City of Lower Hutt's public gallery. It is not a private gallery.

## Screen printing and Ceramic Supplies Ltd

5 Rutherford St, Lower Hutt. Telephone 699-588

P.O. Box 30-588, Lower Hutt New Zealand

**Glazes, Clays, Wheels, Corks, Kilns.**

English Stoneware & Earthenware

New Mini Test Kiln

NZ Hume Crum Body

Harrison Mayer

S.C.S.

Pixie & 2cubic ft to 10cubic ft Kilns

wide selection of

Kickwheel

Pyrometres & Thermocouples

Harrison Mayer Glazes

Cobcraft, C.C.G.

Cones & Corks

Leach

also  
Electric Wheels

Catalogues On Request



### Summer School

A summer school will be held at Massey University, Palmerston North from 15 to 24 January.

The tutors will be

Roy Cowan on ceramic sculpture and glaze technology

Brian Gartside on handbuilding

Mirek Smisek on wheel throwing

Stan Jenkins on drawing as an aid to vision and decoration.

Enquiries to Massey University Extension.

### Kiln building

#### for the new generation of potters

Cowan kiln designs for what Roy Cowan calls the smallest "big" kilns were brought up to date and published in N.Z.

Potter in 1971. We still have back copies of this issue, Vol. 13/1.

Other back copies available are Vol 12/1, 13/1 and 15/1 and 2.

Waihi Beach. Advice sought of good stoneware potting clay, East Waikato, Thames Valley district. Would also like to meet other Potters in District. George Hurley, 86, Main Rd., Waihi Beach.

### Firing with gas

Pottery In Australia have put out two booklets on gas fired kilns which sell for 50c. One is by Les Blakeborough called "Gas Kiln (Catenary Arch)", reprinted from Vol 5 no2 of **Pottery In Australia**. The other is "Cooking with Gas", a top-loading kiln plan and description by Ivan Englund, (also a reprint.) These can be obtained from the editor, 39 Mary Street, Longueville 2066, Sydney.

# FOR SALE

For Sale  
Pottery. House. Coromandel.  
Consists new, three chamber kiln, 150 feet approx. Fired only once to date, "excellent results". New studio (not shed). Lots of outdoor working area. Sunny position.  
House large, old colonial, within 1 mile of Post Office. All-electric 1500 sq ft plus attic bedroom. Verandahs all round. Has just had extensive renewals and repairs. Private section with about half acre of Crown Land adjacent.  
Price \$27,000. Some finance available to approved purchaser.  
We would prefer sale to a potter.  
Contact Gerry Greenwood, Coromandel, or phone Coromandel 536.

**Auckland's Studio Potters Group** has 509 members. In Christchurch there are 206. Does that make around 2000 active potters throughout the country? If so, more people could be subscribers to this magazine. We depend on your support.

### Conservation week

**"Only when the divine respect of green power, only when the love of vegetation becomes part of us all, only then we can improve, step by step our dying environment"**

Hundertwasser

For internationally known artist Hundertwasser, New Zealand represents something like the last earthly paradise, as yet largely unmarked by the ugliness of Western civilisation which has resulted in polluted water, a poisoned atmosphere and ravaged forests.

The idea of conservation, of caring for the natural world, has always been a central part of Hundertwasser's message. His favourite colour is green symbolising living things. He likes spirals and curving lines which he sees as more natural than the characterless blocks man has imposed on himself in technological cities.

For this reason he agreed to do a painting and donate it to be sold as a poster marking conservation week in New Zealand.

Hundertwasser himself subsidised the printing of this poster in eight colours with metal imprints in three colours. He did it in the cause of conserving New Zealand.

### Forthcoming exhibitions

Graeme Storm at Dowse Art Gallery, Lower Hutt 25th October '74 — 15 November  
Muriel Moody and Len Castle both at the Dowse late next year

Jennifer Shearer, Carol Wilson, Dinah Wright (batik), Antipodes Gallery Wellington 27th October '74.

Vases, platters, planters at Alicat, Auckland March '75

Winter pots, casseroles, stewpots, ramekins and romatophs at Alicat Auckland May '75

Porcelain Alicat, Auckland August '75

Erotic ceramics Alicat, Auckland November '75

*If you want to make an announcement in this column you should send us the information three months in advance.*

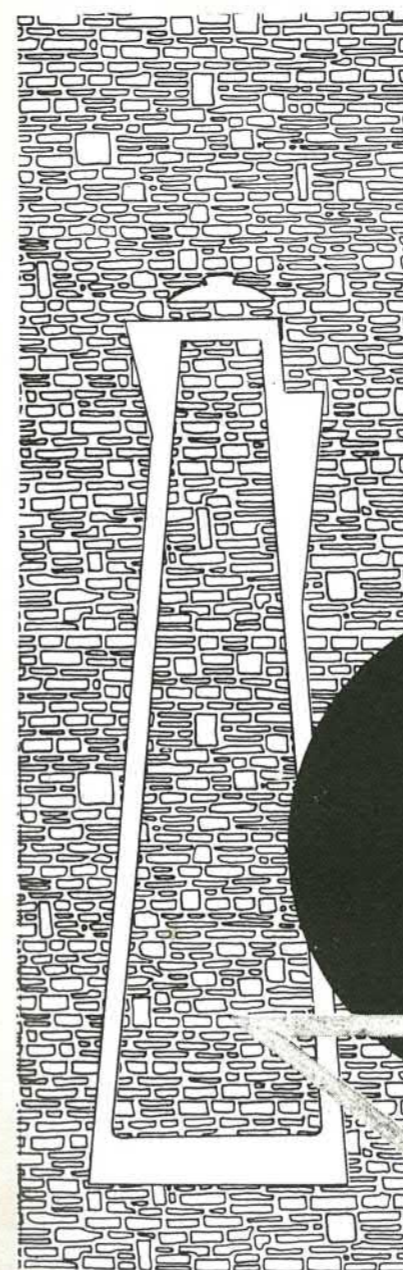

## ALL POTTERY REQUIREMENTS

KILNS

BRUSHES

KILN FURNITURE

CLAY

OXIDES

TOOLS

## ALL RAW MATERIALS

**NORTH ISLAND**  
ALL POTTERY SUPPLIES  
BOX 709  
AUCKLAND

73 CAPTAIN SPRINGS RD  
TE PAPAPA

**SOUTH ISLAND**  
POTTERY; METAL ENAMELLING; CHINA PAINTING.  
BOX 22496  
CHRISTCHURCH

TUAM St  
CHRISTCHURCH

WRITE FOR OUT CATALOGUE  
AND PRICE LIST

## SMITH & SMITH LIMITED

NZ AGENTS FOR WENGERS MATERIALS FOR CRAFT POTTERY.

### COBCRAFT POTTERY EQUIPMENT

**COBCRAFT KICK WHEEL** Smooth and silent action. Changeable 12" wheelhead. Fully adjustable to suit individual requirements. Left or right kick easily converted. Compact rigid steel frame. Specially designed and accurately balanced flywheel. Ball bearings and housing exceptionally sturdy and maintenance free. On wheels for manoeuvrability. A superb wheel to last a lifetime.

**COBCRAFT POWER WHEEL** Infinitely variable speed, on 220 r.p.m. Operated by either foot in sitting or standing position. Handles 35 lb. clay with ease. Fully enclosed drive; 12" changeable wheelhead. Compact rigid steel frame. Adjustable timber seat. Jiggers available.

Can be manufactured to individual requirements.

### SMITHKILNS

ALL KILNS FIRE TO 1300° STONEWARE.

**NO 1** Frontloading 1 cu. ft.  
3½ K.W. Single Phase.

**NO 2** Frontloading 2.2 cu. ft.  
6 K.W. Single Phase.

**NO 3** Toploading 2 cu. ft.  
6 K.W. Single Phase.

**NO 4** Frontloading .21 cu. ft.  
2.3 K.W. Single phase test kiln

**NO 5** Toploading 3.5 cu. ft.  
9 K.W. Single phase







... published twice yearly by the editorial committee