

# Piper





# 'We Promise Satisfaction'

## SLABROLLER

The best available  
Recommended by  
Peter Stichbury

Variable adjustment from 0-6cm (2 1/2 in)

**MONEY BACK GUARANTEE**

Reasonably Priced

Available only from Furnace Engineering

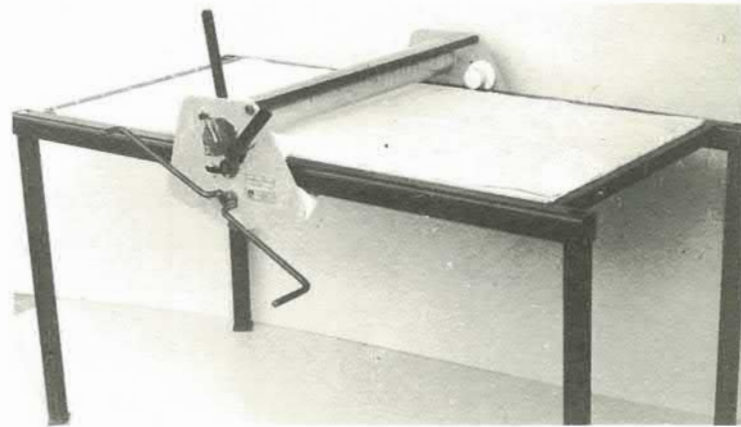

Easy to fire

Consistently

Better

Results

### Kilns for Every Purpose

- Pottery and Raku
- Ceramics
- Porcelain dolls
- China painting
- Enamelling
- Crucible
- Glass Kilns

### Suppliers of

- Ceramic Fibre
- Fibre supports
- Fibre glue
- Brick cement
- Gas Burners
- Raku Burners
- Temp Controllers
- Pyrometers
- Slab Rollers
- Kiln Elements for most kilns
- Kiln Repair and Relining
- Banding Wheels
- Press Moulds
- Extruder with Stand



Gas & Electric Kilns. From 0.6 cu.ft. up to 30 cu.ft.

**FURNACE ENGINEERING** 1986 LTD

6 Holmes Road, Manurewa.  
P.O. Box 136, Manurewa. Ph. 267-2661



Element Support System

- Kilns can be stack bonded or partly built in brick



NEW ZEALAND POTTER  
VOLUME 33: NUMBER 1: 1991

**Editor:** Howard S. Williams  
P.O. Box 147, Albany, N.Z.  
Phone: (09) 415-9817

**Advertising:** Penny Evans  
P.O. Box 881, Auckland, N.Z.  
Phone: (09) 458-831  
Cecilia Parkinson  
Phone (09) 415-9373

**Subscriptions, Publisher and Distributor:**  
NZ Potter Publications Ltd  
P.O. Box 881, Auckland, N.Z.  
Fax (09) 393-247

**Managing Director:**  
Cecilia Parkinson  
**Design:**  
Cecilia Parkinson, John Parker,  
Howard Williams

**Typeset by:** Mills Typeset Ltd  
Tel/Fax: (09) 605-250  
Auckland 3, N.Z.

**Paste Up:** Sheena Reeves

**Printed by:**  
World Publications  
Singapore

**Copy Deadlines: 1st day of February, June, September**  
**Issued:** April, August, December  
**Price:** \$8 per copy incl. GST  
Annual Subscription: \$24 incl. GST  
Overseas Subscriptions sent surface mail: \$NZ28.50

**Advertising Rates:** GST not inc.

**Display: 4 colour:**  
Back cover: \$1650  
(Min. 3 issues)  
Full page: \$759. Half page: \$550  
**Display: Black and White**  
Inside front/back covers: \$532  
Full page: \$485. Half page: \$295  
Quarter page: \$179

**Potter's Market:**  
Full page: \$418. Half page: \$253  
Quarter page: \$154.  
Eighth page: \$93

**Classified:** 55c per word.  
Minimum 10 words.  
Cash with order.

Finished art work must be supplied or above rates will be added to.

PRICE \$8 inc. GST  
ISSN 0113 - 583X

# IN THIS ISSUE

<b>THROUGH THE FILTER PRESS</b> <i>Howard S Williams, Editorial</i>	2
<b>THE BUILDING OF A WALL</b> <i>Eileen Whittington describes the Manurewa Pottery Club Project</i>	6
<b>THAMES SOCIETY OF ART AWARDS</b> <i>Julie Peck reviews this for the Thames Star</i>	8
<b>ZIMBABWE</b> <i>Robyn Stewart's cultural exchange in Africa</i>	10
<b>'TAKES ONE TO KNOW ONE'</b> <i>Brian Gartside continues his regular feature</i>	12
<b>ARTE APERTO</b> <i>Lynda Harris works in an Italian studio</i>	14
<b>WAIKATO POLYTECHNIC</b> <i>Students' ceramic work from 1990</i>	17
<b>NEW FACES IN COROMANDEL</b> <i>Howard Williams visits old friends</i>	18
<b>THE COLLECTORS</b> <i>Why architect Ron Sang buys pots and other art work</i>	20
<b>BOOKS</b> <i>New publications reviewed by Howard S Williams</i>	22
<b>MAU MAHARA</b> <i>NZ Crafts Council Exhibition</i>	23
<b>CRAFT POTTERS NELSON INCORPORATED</b> <i>Bob Heatherbell reviews their 17th annual exhibition</i>	24
<b>LA BORNE EN FEU</b> <i>John Lawrence attends a ceramics symposium in France</i>	26
<b>RECENTLY SEEN</b> <i>Our colour picture gallery</i>	29
<b>OTAGO PENINSULA TRUST</b> <i>Premier Ceramic Award is announced in Dunedin</i>	32
<b>BONSAI</b> <i>Making special pots for special trees</i>	33
<b>STARTING FROM COLD</b> <i>Elizabeth Woodfield re-designs a vapour jet burner</i>	35
<b>GALLERY GUIDE</b> <i>A countryside listing of pottery shops and galleries</i>	38
<b>POTTERS MARKET</b>	39

### IN NEXT ISSUE AUGUST 1991

Middle Fire Glazes, by John Parker  
Catherine Anselmi — is there Life after Crown Lynn?  
Selling Pots, from a dealer's point of view  
Brian Gartside uses local materials

### COVER PHOTO

Richard Parker, guest potter at Waikato Society of Potters exhibition. Terracotta vase with white slip and dotted glaze. Photo by David Cook courtesy Waikato Museum of Art and History, Hamilton.





# THROUGH THE FILTER PRESS



Don Reitz

## CLAYAZART

Rotorua, June 14-16.

Many potters will remember what may well have been a high point in their potting life — when they met, watched, listened to and laughed with **Don Reitz** during the *NZSP* symposium held at the *Palmerston North Teachers College* in the summer of 1981.

This symposium proved to be a turning point in the development of the society, as well as in the pottery careers of many people. Don Reitz was the catalyst for great and lasting changes and he is coming back this June!

Many potters will also remember the powerful images and emotions produced in Rotorua in 1985 during the *ClayAzArt* International Conference. The inimitable **Peter Voukos** will not be returning, but most of the *ClayAzArt* team are, backed up by some special local potters.

June 14-16 is going to be a stunning time for us, as the *ClayAzArt* International Conference will be on again in Rotorua, this time, alongside our own *New Zealand Society of Potters* National Annual Exhibition held in Rotorua's *Bathhouse Art Gallery*.

The conference is sponsored by the *Northern Arizona University Art Gallery* and will be conducted by one of its ceramic tutors **Don Bendel**. He

has taken responsibility for many *ClayAzArt* conferences and ceramics workshops in USA, Japan, Finland, Australia as well as here. He has developed unique clay bodies and decorating techniques, particularly in his special field of ceramic sculpture.

Don Bendel



Demonstrators from the States will be **Don Reitz** who in a *CERAMICS MONTHLY* poll was voted "one of the 12 best ceramic artists worldwide." He has been a major force in the development of studio ceramics in most western countries, a regular exhibitor, mural maker, workshop tutor, and of course international juror — he was the judge for the *Fletcher Brownbuilt Award* of 1984. I still hear Don Reitz quotes being used by potters even today!



Jim Leedy

Sculptor **Jim Leedy** returns as a demonstrator, and if sponsorship can be found he hopes to fly one of his enormous *Sky Art* fabric pieces while he is here. He is internationally known for his prints, drawings, ceramic and sculplural works as well as his *Sky Art* pieces which have been flown between high buildings or from enormous balloons in many USA cities. He is currently head of the *Kansas City Art Institute's* sculpture department.

**Yukio Yamamoto** will be a newcomer to us. He is a master ceramist with studio and wood-fired kilns in Himeji, Japan, and is noted for thrown works as well as large platters, sculptural forms and interpretive calligraphy and painting. He has built traditional wood-fired kilns in Taipei and at the *Northern Arizona University*. He has worked in Spain and the USA in studios, conducted workshops and held exhibitions.

Another famous member of the team **Rudy Autio** will be holding informal discussion sessions, while the New Zealand input will be from **Barry Brickell** and **Chester Nealie**, both of whom will also be operating a pre-conference firing in the *Driving Creek*, Coromandel coal-fired salt glaze kiln.

The venue for all this magnificence is the soundshell auditorium on the lakeshore, Rotorua; the registration cost, \$175, plus accommodation etc; the address to write to for registration forms and further information;

**New Zealand Travel Office**  
67 Fenton Street  
Private Bag  
Rotorua  
Ph: (073) 485-179

All this is being co-ordinated at the New Zealand end by **Mark Chadwick** of Te Puke who was responsible for the first *ClayAzArt* visit. He is hoping for a high registration for places at the conference as this helps with finance through such agencies as *QE II Arts Council*, and means securing the possibility of future *ClayAzArt* conferences here. Many Americans will be travelling here to attend as well as our own potters. Write, or phone immediately to secure your registration.

## BRISBANE

Australia also holds ceramics conferences, the next major one being the Sixth National Ceramics Conference held at *Griffith University*, Brisbane from 30 June to 6 July. It is run by the *Queensland Potters Association* and will include many workshops as well as discussions, lectures, tours and exhibits, and social events. Registration from:

**Secretary**  
6th National Ceramics Conference  
PO Box 231  
Broadway  
Queensland 4006  
Australia

## CONGRATULATIONS

... to Titirangi potter **Len Castle**, who some time ago became a *CBE* for his services to pottery, as he was further awarded the *New Zealand 1990 Commemoration Medal* at the end of last year. A most impressive certificate came signed by the then Governor-General, **Sir Paul Reeves**, the then Prime Minister **Geoffrey Palmer** and the thenandstill Herself, **Elizabeth R.**

This medal too, was awarded for his services to New Zealand, but it is typical of Len when he says "Naturally I was delighted to receive this official honour, but I regard it not as a personal award, but one that has been made to the pottery/ceramic movement in New Zealand in recognition of its strength and dynamism. I'm just the medal carrier."

Congratulations also to **Moyra Elliott** for being specially invited to show ceramic work at the *5th International Triennial of Ceramics* in Warsaw, Poland.

## ITALY REQUESTS ...

**Moyra Elliott**, co-ordinator for the *Fletcher Challenge Award* has had a request from one of the most prestigious galleries in Italy for information on NZ ceramic artists who would be interested in sending work there for a special exhibition.

People who are interested should send a full *CV* and professional slides of their ceramic work to her, as she will be able to courier them to Italy free of charge. Send to Moyra Elliott, c/o:

**Auckland Studio Potters Centre**  
PO Box 13-195  
Onehunga

**George Sempagala**, potter from Uganda was the guest artist for *Kaiku*, an exhibition of the work of established and emerging Maori potters. It was held on the mezzanine floor of Auckland's *Chase Plaza* and was curated by **Baye Riddell** and **Manos Nathan**. The photos are from the opening ceremony for *Te Koanga*, Spring Festival of Maori Arts, held at *Tatai Hono Marae*, Auckland, September 1990.

## OBITUARY

It was with great sadness that we heard of the death in February of one of our pioneer potters, **Elizabeth Lissaman, OBE**.

Elizabeth was the author of *Pottery for Pleasure* published by *Reed* in 1969 and was awarded the *OBE* in 1982 for her services to pottery. She had her first pot fired by the *Mirimar Brickworks*, Wellington in 1920 and as she was still making pots last year, she must have set a record for this country of actually throwing pottery for 70 years.

Work by Elizabeth Lissaman will be on display as a major retrospective collection at the *NZSP* national exhibition alongside the *ClayAzArt* symposium in Rotorua — see notification following.

A full article with photos of Elizabeth's brush decorated earthenware pots was published in *NZ POTTER*, vol.29, no.3, 1987.



Baye Riddell with Georgina Kirby

Photos by Gil Hanly

Barry Brickell, George Sempagala and Helen Mason

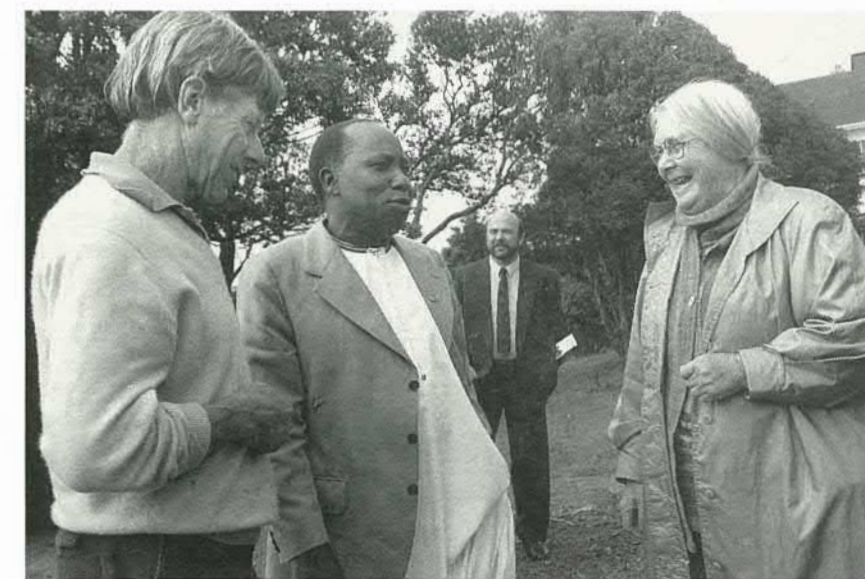



## QE II ARTS COUNCIL GRANTS

### Short Term Study Project

**John Crawford**, \$5,000 to undertake a four week tour of Germany, Italy and France, exhibiting ceramics and paintings and compiling a teaching programme.

**Lynn Spencer**, \$5,000 to develop large jug and urn shapes, and experiment with different clay bodies to create differing surface effects.

### Major Creative Development

**Christine Boswijk**, \$15,000 to hold an exhibition at the *Suter Art Gallery*, Nelson in March 1991, continuing two major elements, philosophical and technical.

**Peter Oxborough**, \$14,000 to further develop new directions in ceramic based multi-media sculpture with a view to mounting a major exhibition at the *Crafts Council Gallery* in 1992.

**John Parker**, \$15,000 to explore new directions in researching the effects of special light, UV etc, on chemicals in clay and glass.

### Artist Promotion scheme

**Peter Henderson**, \$3,000 to obtain full ownership of a 25cu ft diesel kiln and convert it to LPG, and purchase a *Shimpo* potters' wheel.

**Kari Shadwell**, \$2,000 to undertake a 3 month study tour of Vancouver and London visiting galleries, museums and institutions offering arts and crafts courses.

### Artist in Residence

**Julia van Helden**, 6 months at *Hawkes Bay Polytech*, \$12,000.

**Ralph Herschell Levy**, 3 months at *Waikato Polytech*, \$6,000.

## LETTER TO THE EDITOR

The writer of this letter, **Emmanuel Cooper** is a joint editor with **Eileen Lewenstein** of *CERAMIC REVIEW* and also edits other publications — see our bookreview pages. He writes re **Brian Gartside's** article, page 16, *NZ POTTER*, vol 32, no 2, 1990:

I enjoyed **Brian Gartside's** *Ha, Ha, Ha, You and Me* on the wonderful qualities of red iron oxide to produce a variety of deep rich oranges and browns in the electric kiln. As I work almost exclusively with stoneware and porcelain

fired in the electric kiln the search for a reliable tenmoku (**Frank Hamer** in his authoritative *Dictionary* spells the glaze this way) never ceases. Brian's use of borax frit in the glaze acts as a highly effective flux and can produce quite startling tans and blacks according to the thickness of application and the clay body. My recipe, which is effective from about 1240°C in the electric kiln, and which is given in the book **Derek Royle** and I wrote, *Glazes for the Studio Potter*, is:

Feldspar	50
Flint	15
Whiting	10
Borax Frit	25
+ Iron oxide	10

Maybe it will be of interest and use to potters in New Zealand. Brian's article gives two refiring temperatures, 1260°C and 1060°C. Which one does he use?

*Emmanuel Cooper*

**Brian Gartside** replies: The refiring was to 1060°C, the higher temperature given was an unfortunate typing error. This lower temperature also gives me the opportunity to use earthenware glazes over the top of the previous stoneware glaze.

# VENCO PRODUCTS

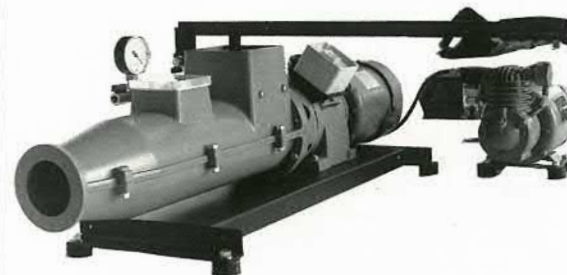

## Export Price List 1 April 1989

Note: All prices in Australian dollars — ex Works — Crated in Export quality crates. Cost Insurance and Freight (C.I.F.) Pricing upon application.

### STANDARD PUG MILLS

75 mm NOZZLE 136mm BARREL SINGLE PHASE	\$1050.00
125 mm x 160 mm NOZZLE TWIN SCREW SINGLE PHASE	\$5500.00

### DE AIRING PUG MILLS

75 mm NOZZLE 136 mm BARREL SINGLE PHASE	\$1650.00
87 mm NOZZLE 150 mm BARREL SINGLE PHASE	\$2300.00
100 mm NOZZLE 200 mm BARREL SINGLE PHASE	\$2900.00

G.P. & G.F. HILL PTY LTD

Manufacturer:

**VENCO PRODUCTS/  
WESTWIND TURBINES**

29 OWEN RD, KELMSCOTT, WA 6111, AUSTRALIA  
PHONE (09) 399 5265  
TELEX AA 92881 (PUBTL) PE 1366  
FAX 61-9-497 1335

## Call For Entries FLETCHER CHALLENGE CERAMICS AWARD 1991

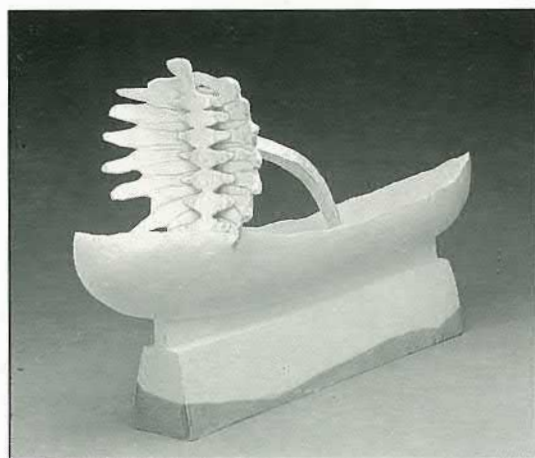

1990 entry from Kyoko Hori, Japan

**Closing Dates for N.Z. Entries are  
Friday May 10 at the A.S.P. Centre  
or Monday May 14 at the  
Auckland Museum**

**Exhibition: Auckland Museum  
Friday May 31 to Sunday June 30**

## POTTERS CLAY (NELSON) LIMITED

P.O. BOX 2096, 42 QUARANTINE ROAD, STOKE, NELSON  
TELEPHONE: (054) 73-397 AFTER HOURS: (03) 547-3397

### STONEWARE

GB2  
RMK3  
OTAGO POLY  
No. 18  
WHITE SLAB  
SC80 & SC50  
HGB & PCW

### LOW FIRING STONEWARE

LF18  
GEF  
No. 21

### EARTHENWARE

1100 Red  
E2  
RKF  
PC Red

### DISTRIBUTORS

Homecorp Mitre 10 .....Dannevirke  
C.C.G. Industries .....Auckland  
Western Potters Supplies .....Auckland  
Western Potters Supplies .....Hamilton  
Glaze Away Potters Supplies .....Palmerston North  
Coastal Ceramics .....Paraparaumu  
Bay Potters Supplies .....Havelock North  
Wellington Potters Supplies .....Wellington  
Cobcraft Potters Supplies .....Christchurch  
H.L. Familton .....Oamaru  
Courtyard Pottery .....Dunedin  
South Street Gallery .....Nelson  
Potters Clay (Nelson) .....Nelson

and most Placemakers branches

\*\*\* ABBOTS \*\*\*

# WHITE EARTHENWARE

NOW AVAILABLE

a premium quality white earthenware clay

\* excellent throwing clay \*

\* ultra white \*

\* fits Abbots clear glaze \*

# SOUTHERN CLAYS LTD

P.O. Box 6323, Dunedin, Telephone (024) 776-229



# THE BUILDING OF A WALL

Eileen Whittington, Manurewa



Working on the mural: Howard Williams with Manurewa Potters Club members Rita Zwitter and Colleen Rhodes.

When, in 1989, the suggestion was made to the *Manurewa Potters Club* that they should produce a mural to mark the Sesquicentennial Year, the response was less than enthusiastic. Sesquicentennial Year? They could hardly pronounce it let alone spell it! A mural? What sort of a mural? Where would it go? Nobody had ever made a mural. They forgot about it for a while.

The Potters Club meets weekly at *Nathan Homestead* and includes people aged from 20 to venerable 70s, with skills and tastes ranging from tortoise and cottage makers to a few who produce pots suitable for entry into national exhibitions. They are given to sumptuous morning teas and expeditions to other potteries and places of interest, naturally finishing up with sumptuous lunches. Some members are professional potters, some have just about completed their first term at pottery classes, and some haven't made a pot in years, but come along for interest and company. A motley crew!

1990 seemed a long way off in 1989, but the irritating topic of the Mural recurred at every meeting, so a group went to Auckland to look at some murals, to see what might be expected of them. In banks and the foyers of important-looking glass buildings they found murals. They were both impressed and depressed, and over yet another sumptuous lunch they pondered their findings. Most of the murals were designed and made by one, or at the most, two people. How could the club, from its hotch-potch of talents, hope to get any semblance of homogeneity in a mural? Some of the murals were made by Albany potter **Howard Williams**. He was contacted and agreed to help.

By the end of 1989 some decisions had been reached. The mural was to be of tiles, 18cm square wet, and 1cm to 2cm thick. The clay used would be *Abbots White* earthenware, bisqued at 920°C and fired at 1140-1160°C and the theme of the mural — Manurewa and the surrounding areas. The mural would be mounted on a wall in *Nathan Homestead*, visible to all who climbed the wide oak staircase to see the varied art, craft and cultural exhibitions which are displayed and changed very few weeks.

Confidence had grown a little since Howard's demonstration on tile-making.

"Don't worry about diversity," he said airily. "Just let your imaginations run riot. We'll sort the tiles out and rearrange them when they are all done. That'll be the fun-day.

There was obviously a lot of hard work before we got to the fun. Doubts and misgivings still plagued most of the potters. What on earth was interesting enough about Manurewa to go on tiles? The *Historical Society* was helpful, but what history there was didn't seem exactly dramatic. How much imagination dare we use? Some people had a lot more imagination than others.

The mural would be in two sections, the first third centred round a panel of tall ships, with early settlers and Maoris and so on. Then there would be a gap, and the rest of the mural would be centred round a panel of *Nathan Homestead* itself, surrounded by the activities that went on there today. People shook their heads doubtfully. "It's not really my Thing!" "I've never made a tile in my life!" and "Count me out." were some of the comments heard.

And then someone produced a tentative tile! We stood around it marvelling. One tile! We only needed 199 more. Yes, well, maybe we could do something like that. We went away to think.

Things began slowly. Tiles began to appear, were displayed, explained, inspected and admired and we learned a bit of history. More and more potters crawled out of the woodwork. Everyone attended meetings and shared ideas. Photos were taken of churches and buildings, streets, schools and landmarks, and the local library combed for information and pictures. Wednesday meetings were so crowded that morning teas had to be rationed to only one cake each.

We decided to use mainly oxides on the historical area; subdued, like an old sepia photo, but the modern side could be stained and glazed as fancy dictated. Oxides were mixed and tested, and the club's kiln was busy night and day.

Howard Williams, Des Howard and Ian Axtell hang the final panel.



Ian Axtell trims a fixing batten.  
The complete Mural



Ian Axtell and Corrie Paterson make final adjustments.  
Nathan Homestead tiles by Rita Zwitter

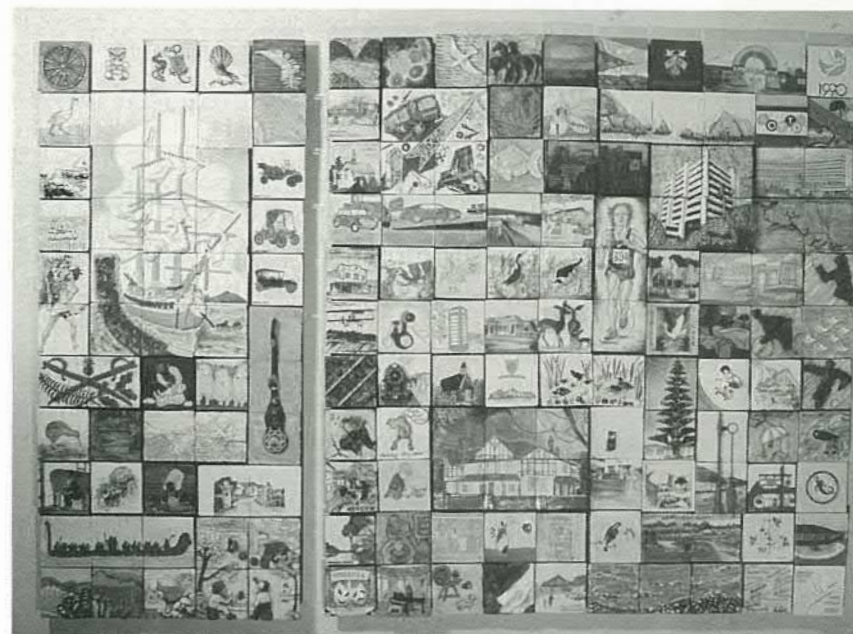

Then the date for the unveiling was fixed. November 2nd. All had to be completed by then. Work redoubled and at any time during the week in the clubrooms people were to be found applying oxides and glazes, loading or unloading the kiln. Our potter-carpenters erected a strong wooden frame on the wall on which the three heavy panels would be hung.

The came the FUN-DAY! All the tiles were spread on the floor of the theatre room and we gathered round to survey the sum total of our collective hard work. It was an interesting, but heterogeneous array. With considerable tact and a master's eye Howard sorted and rearranged, selected and discarded on the basis of content and colour with plenty of comment and criticism from the by-standers, and the mural began to emerge before our eyes.

A tall ship appeared, white sails furled, and around it things Maori and pioneer. On the other side there was *Nathan Homestead*, the eye-catching modern buildings of

Manukau city, **John Walker**, a local celebrity striding down three tiles, setting records, and all the activities going on in the Manurewa area. School crests and shields, rich with symbols, mottos and history were too numerous for the three boards and were mounted separately on a smaller one.

The tiles in place, they were lifted onto the waiting core boards and fixed with heavy duty tile adhesive. Later the heavy boards were lifted into place and edge-framed and the mural was finished.

The deputy major of Manukau did the unveiling with accompanying speeches (short) and wine and food (much longer), and under the floodlighting the wall was, after all, quite an impressive sight.

And for 1990, a year during which the *destruction* of a Wall made international headlines, to have actually constructed one, however small, gave eminent satisfaction to a Manurewa group of potters. ■



# THAMES SOCIETY OF ARTS

## Summer Award Exhibition

Julie Peck, Thames Star

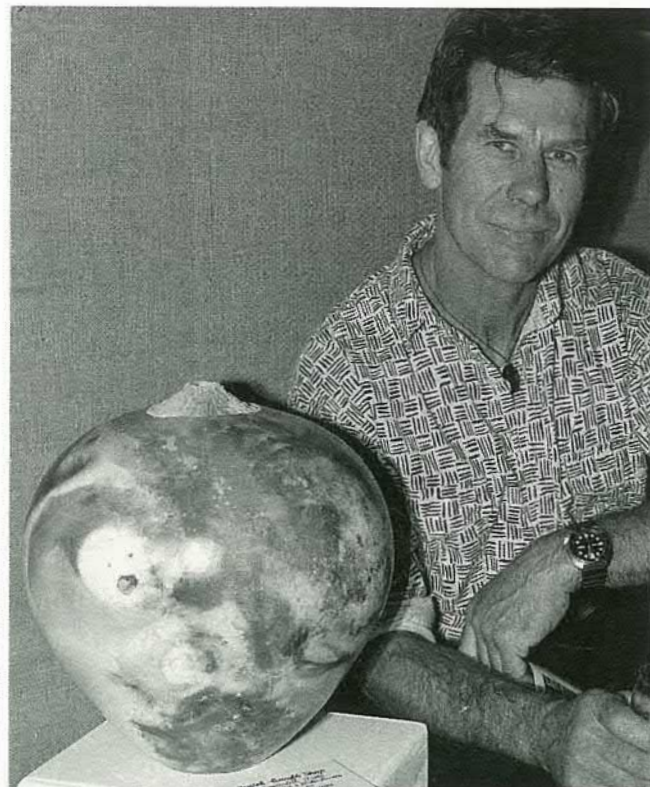

John Macassey, winner of the member's prize.  
Photo by Julie Peck, courtesy Thames Star.

Now in its fifth year, the Thames Society of Arts Summer Exhibition has grown far beyond its founders' expectations.

When the idea of an award exhibition was first suggested, most art society members felt it was too ambitious, but **Ralph Donkin**, society president at the time, was sure he could get the support of Thames businesses and make it a viable proposition.

"A group of us thought that as we had such an influx of visitors through the gallery during the summer, an added attraction would benefit the gallery and increase sales for members. I discussed the idea with **Peter Calloway** of the Thames Auction House. He listened to me without saying a word, then said he would give me \$500 as a first prize for a painting. He thought it was a great idea, and that was the turning point."

Ralph Donkin then approached five other businesses and within a day had all the money, so he went back to the committee and said "Here are the prizes."

This year's society president **Norma McBurney** said the original idea of having the exhibition was to raise money when the society began taking over responsibility for the building's maintenance. Now the exhibition makes the art society a reasonable profit every year, which goes towards buying equipment and building maintenance.

"The idea was also to hold a summer exhibition open to all New Zealand, bringing work in from outside the peninsula, which we would not normally see. This would help raise the standard of our own people."

Pottery became a major part of the exhibition when the local newspaper, the *Thames Star* put up a \$500 first prize. Advertising for the exhibition goes further afield every year with the result that entries are now coming from all over the country. Most potters from outside the area send in small, easy to handle pieces, unless they can bring them in themselves, as did this year's winner **Ted Kindleysides** who brought his entry *Pacific Pot* in himself.

"Over the years the exhibition has been held, the standard of pottery has increased dramatically." Norma McBurney said.

Ralph Donkin agreed the standard had improved. "Entries have increased every year in the pottery section and have also changed. They have moved away from the more conservative entries we got at first and we are seeing vastly different styles, which is good. It gives the visitor and the local artists a wider view. It is good for our potters to come in and see different techniques being used 'in the flesh', rather than just seeing them two-dimensionally in magazine pictures. They can look at them, pick them up, feel them."

**Celia O'Brien**, a potter who teaches classes there, said pottery became part of the society's programme when it first leased the old North School building just north of Thames in 1974. As a potter she finds the summer exhibition very valuable.

"When I first started pottery I used to go to every weekend school I could get to, to learn from what other people were doing. Now the exhibition brings it right to our doorstep and we can see what people in other places are doing and get new ideas. It's not copying, but getting new ideas to bring our standard up. You look at other people's pots and want to strive to do better. I am all for summer exhibitions like this one of ours, which has also put the Thames Art Society on the map."

"Pacific Pot", Ted Kindleysides, \$500 Award.



"Exercise Class", Gary Nevin, \$300 Award.

**Raewyn Gray**, another pottery teacher with the society said the pottery facilities available at their building were a great community asset.

"A lot of work has gone into them. We started off using second hand kilns and donated equipment. As the years have gone by, everything has been updated. We now have a new 8 cu ft electric kiln, partly funded by a lottery board grant through the Northern Regional Arts Council. The society has just upgraded the pottery room, installing work benches around the sides and putting four wheels into the centre of the room — a major rewiring job. Also available to potters are a slab roller, pug mill and glazing facilities."

Raewyn Gray is a little concerned in case the exhibition starts to lose local input. "While it is good that the exhibition is becoming increasingly well known as a national event, local potters may be starting to feel they can't compete. It's important to improve standards, but if it becomes too professional it could squash the enthusiasm of up and coming potters. It is good for them to have something they can aim for."

The exhibition has always been a success story for the exhibitors and Ralph Donkin hoped it was the same for the businesses which supported them.

"We could not survive without their support, so I hope they get something from it. Some are very generous with their prize money and without that sort of drawcard we would not get so many outside entries."

The Thames Society of Arts Summer Exhibition usually runs for two weeks in January — this year it was from January 17 to 29.

The first prize of \$500 in the pottery section was donated by the Thames Star, second prize of \$300 came from Focus Homes of Kopu and third prize, \$100 came from Thames Plants 'N' Pets. A society member's prize of \$100 came from the Thames branch of Smith and Smith Glass.

Judge **Howard Williams** chose *Pacific Pot* from Huia potter **Ted Kindleysides** for the first prize.

Second place went to Cooks Beach potter **Gary Nevin** for his sculptural pieces *Exercise Class* and third to **Janet Smith** of New Plymouth for her *Ties*, a raku bowl laced with wire.

**John Macassey** of Tapu won the member's prize with his pit-fired burnished pot *Fire and Earth Impressions*.

The painting section, judged by **Karen Butterworth**, an assistant professor of art at Auckland's Whitecliffe Art



"Ties", Janet Smith, \$100 Award.

*School*, was won — for the second year running — by Huia artist **Ilsa Posmyk**, who also happens to be **Kindleysides'** wife. Their daughter **Verity Kindleysides** also entered a work in the souvenir design section, just to keep the family well represented! ■

For information on next summer's exhibition write to:

**Norma McBurney**  
Thames Society of Arts  
Old North School  
Tararu Road  
Thames

Photos by Howard Williams.

The Thames Society of Arts Exhibition.





# ZIMBABWE

Robyn Stewart, Waiwera

Photos by Robyn Stewart



The pottery in modern use in Zimbabwe can be traced back through various traditions discovered during archaeological excavations in the country. Basic concepts of style and design can be followed through the centuries from 300AD to the beginning of the colonial era. The distinctive decoration of particular cultures, be they dentate stamps, incisions, cross-hatchings, herringbone, chevron, lend a definite character to Zimbabwean earthenware.

The decorative quality appears to have declined with colonialism and the introduction of mass-produced, durable containers and vessels. Decoration is now often applied with modern house paints. Although this traditional craft, handed down from mother to daughter for generations, is still practised in many areas, rarely is pottery of note seen.



Clay deposits are usually located around rivers or ant-hills. Dry clay is ground into powder, sifted and winnowed, then moistened for use. Pots are made by coil and pinch methods and fired four days later.

Graphite slip is common in some areas, where the mineral is washed down from graphite bearing rocks in the rivers. It is applied to leather-hard pots with the fingers and burnished lightly with a pebble to produce a deep silvery black finish. At times the whole pot is covered, at others, only in a pattern on the red earthenware.

As a general rule all modern pottery used for cooking does not have any decoration, whereas vessels for drinking beer or water and those used to serve food in, do.

The decorative themes applied to pots easily identify their cultural and social traditions. The use of chevron patterns and vertical stripes which contrast graphite blacks with haematite red ochres, and incised patterns of bands, triangles and vertical stripes, are typically Shona tradition and are immediately recognised by other Africans.



Not only are these decorative techniques easily identified with pottery of the past, but so are shapes and sizes, all of which fit into the pattern of Zimbabwe Iron Age societies, as well as those of the more recent agriculturists. Until the colonial era there had probably not been any major change in economy or technology for 2,000 years.

In 1990 I was invited to Zimbabwe to be one of seven international judges for the annual multi-media *Zimbabwe Heritage* exhibition. An interesting and challenging experience; to reduce 4,000 entries down to 400 exhibits of sculpture in stone, wood and metal; ceramics, textiles, painting and photography.

After this task was completed I travelled through the country conducting workshops under the auspices of the *National Gallery*. Six workshops in all, covering art students and teachers (both black and white), hobby and studio potters — and rural women potters whom I enjoyed immensely.

In Gweru, 28 women from 8 districts had been assembled together at the *Methodist Mission* centre for four days. In this type of workshop my value was as a catalyst for women to talk and work together. They saw some merit in their skill of pottery making, as their own community leaders were showing an interest in this craft for the first time. The few new ideas I presented were welcomed but, I believe, as of minor importance.

Rural women's life is one of harshness and poverty. However they often sang as they worked and danced spontaneously once the firings were under way. Here the pots were fired in a hole lined and covered with dried cow-dung, with some women adding maize cobs as well. Firings were completed in 1½-2 hours.



Another workshop was held at Masvingo in a Shona Village, close by the *Great Zimbabwe Ruins* — a tourist area where the most sophisticated, well-executed pottery in the country is to be found. A good market here, and the younger women well aware that work of a high standard can earn them a good living.

Small quantities of graphite covered pots were constantly being fired alongside meals of beef and sadza — the staple diet of maize meal which looks and tastes like wall-paper paste, but is very nutritious.

Pots are warmed, then a tepee of msasa bark built over them. When this has burnt down, about 2½ hours, the pots are considered fired. They are very fragile, but definitely ceramic. A longer or hotter fire results in a much duller graphite surface.

My 3½ months were crammed full of memorable experiences. The form and colour of the African landscape and the people, made a lasting impression upon me, which I feel will influence my own work in the future. More so than any other country in which I have travelled.

I gratefully acknowledge the *QE II Arts Council* travel grant which covered the air fares to and from Africa, for myself and an exhibition of my pots. ■

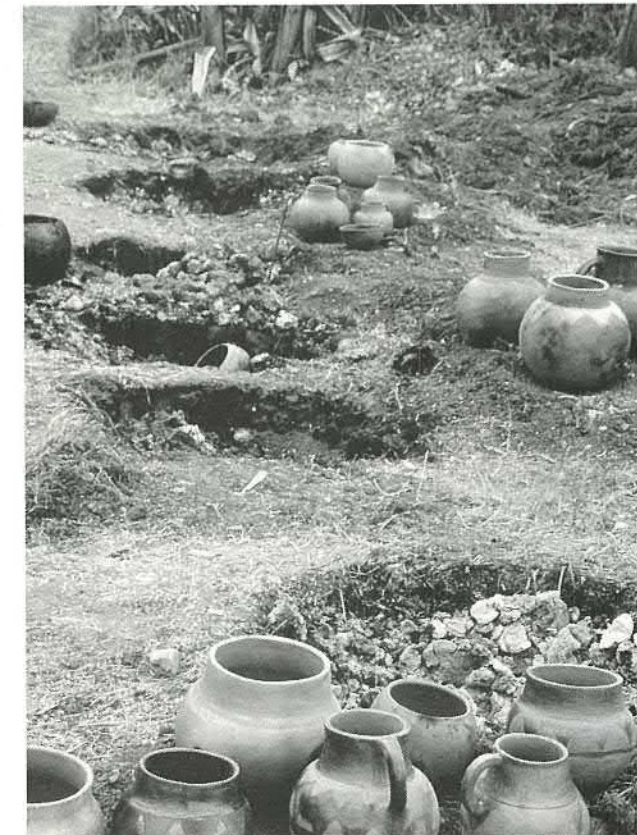

# COASTAL CERAMICS

## POTTERS SUPPLIES

124 Rimu Road Paraparaumu NZ

Tel 058-84377 Fax 058-73107

Hours 8-4.30 Mon to Fri,

8-12 noon Sat

Mail Order throughout NZ

Write for free catalogue

Manufacturers of

Talisman Pottery Equipment -

including electric potters wheels & seats, batts, lotus & 15" wheelheads, banding wheel bases (takes all Talisman wheelheads), slabrollers, light pugmills, extruders, rotary & hand sieves & spare screens, test sieves, plastic & aluminium woks, glaze & slip stirrers for electric drills, hand operated glaze mixers and electric spinning wheels

We also stock a full range of:

- Clays- (NZ) Potters Clay, Southern Clays, Western Potters (UK) Potclays, Pottery crafts
- Raw Materials
- Glazes, stains, lustres, underglaze colours, underglaze pencils & crayons, Aristocrats (overglaze), China paints & enamels
- Teapot handles, winetaps, oiled thread, gloves & mits, masks & goggles, spray units
- Corks
- Brushes & tools - a very comprehensive range
- Glaze & Raku tongs, banding wheels, wheel grips, scales
- Moulds
- Kilns - Cobcraft & Cotter
- Kiln Furniture, temperature indicators & controllers, cones
- Potters wheels - electric & kick - Talisman, Cobcraft, Cowley, Shimpo, Venco
- Pugmills - Talisman, Ratcliffe, Shimpo, Venco
- Extruders - Talisman, Cowley, Coilex
- Slabrollers - Talisman
- Books & magazines - a wide range. Magazines include "NZ Potter", "Pottery in Australia", "Ceramic Review" UK, "Ceramic Monthly" USA - subscription available.

WRITE OR RING FOR FURTHER INFORMATION



# TAKES ONE — TO KNOW ONE

Brian Gartside operates *Ramarama Studio Pottery and Gallery*, 2km west from the southern motorway at Ramarama, Drury, RD 3.

- Have you ever noticed how some people are always drawn to the most complex and 'advanced' almost before they begin? You've only to watch some children trying out a new computer game. See them attracted to the 'high skill' levels first. The last thing they want to do is start at the beginning, or (even worse) read the instruction manual.
  - I have somewhat of a problem in that fashion, myself, I tend to read a magazine or 'browse' a book backwards from the last page to the front. It's the same with new gadgets and appliances, always expecting to use the camera, TV, VCR, tools or washing machine first time, and without resorting to the manual. I have a friend who percolated the instructions of his new coffee-making machine, following this perverse method of learning. Printing ink and papier-mache flavoured coffee gave him cause for thought, but didn't cure him.
  - Of course I rationalise this attitude by saying it's perfectly natural, that people have different methods of learning and that, in any case, the concept of "beginner, intermediate and advanced" suits teachers more than learners.
  - So it is with glazes. I wonder how many people, like me, skipped the basic bit about glaze trials that involved **only one material**. I have to admit that it sounded interesting, but I never really got round to it. I wanted to get on to *real* glazing.
  - There *is* one thing about reading a book backwards — if it's interesting enough you do eventually reach the first page. So now I present the first of my ideas, about the melting of single materials — in this instance fired to 1260°C (cone 6).
- 1 This shows **Petalite**, a kind of **Feldspar**, as a white powder which is only just beginning to melt at the edges. All these tests, before firing, looked powdery like this.
  - 2 **Cornish Stone** is related to **Feldspar** too. This shows that more melting has taken place.
  - 3 **Feldspar** itself shows its first stage of melting.
- Firing to a higher temperature produces more fluid melting in most cases.
  - More colour would be produced if stains or oxides were added. No colourants were used in these examples.
  - Depending on where you live in the world, availability of the illustrated minerals will vary.
  - It is probable that my next article will illustrate some more 'close to home' materials.
  - Does Amblygonite really exist? ■



- 4 All the books tell you that **Nepheline Syenite** has a greater fluxing power than **Feldspar**. Here is proof.
- 5 **Strontium Carbonate** is said to perform in a similar manner to **Barium Carbonate**. Compare this with No. 9.
- 6 **Fluorspar** is strong in **Calcium** and **Fluorine**. Fired to 1260°C (cone 6) it is fused and crusty.
- 7 **Dolomite** is very closely related to **Whiting** (No 8). Easy to see!
- 8 This is **Whiting**, or **Calcium Carbonate**. All the white or grey powders produce most surprising and subtle colours. They also react to some extent with the clay surface.
- 9 **Barium Carbonate** is a very hazardous material to touch or breathe in. I was quite surprised that such a strong colour developed from the white powder.
- 10 This is the odd one out. I crushed some small sea shells with a hammer.
- 11 **Spodumene**. "Similar to **Petalite**, a cousin to **Feldspar**" the books say. Very dis-similar when melted, it seems. Compare with No. 1.
- 12 Yet another close relative of **Feldspar**, **Lepidolite** does behave in an expected way.
- 13 **Lithium Carbonate** melted quite readily with a smooth, but textured surface.
- 14 **Cryolite** produced a dry, crusted melt. Mixed with other materials it produced some very interesting results — later articles will describe.
- 15 **Amblygonite**. I am very keen to find sources of this material. The last few spoonfuls I saw were used in Banff, Alberta in 1990. Of all the materials I used, it alone was the one that most wanted to be a glaze.
- 16 A large spoonful of wood ash produced this melt. Obtained from a wood fire, my guess is that it had rusty nails in it — hence the iron.

Petalite 1	Cornish Stone 2	Feldspar 3	Nepheline Syenite 4
Strontium Carbonate 5	Fluor-spar 6	Dolomite 7	Whiting 8
Barium Carbonate 9	sea shells 10	Spodu-mene 11	Lepidolite 12
Lithium Carbonate 13	Cryolite 14	Amblyg-onite 15	Wood Ash 16
All materials fired to 1260°C (Cone 6)			

I wish to acknowledge the generous sponsorship and facilities offered to me by the *Banff Centre for Arts* in Canada last summer. This article demonstrates a fraction of the developing ideas I can maintain through experiences such as Banff can offer.





# "ARTE APERTO" WORKSHOP IN FAENZA

Lynda Harris, Hamilton

Recently I spent a month travelling in Italy during their late summer visiting ceramic collections and potters in a number of centres. With the assistance of a QE II Arts Council study grant I attended a workshop held by **Emidio Galassi** in Faenza for part of this time.

Galassi holds a series of these workshops throughout the summer at his studio in an old farmhouse in the countryside near Faenza. I had met him on a previous visit to Faenza and hoped by attending this workshop to learn some new approaches to working with clay and in particular hand-building large raku pieces. Galassi is a professor at the *Istituto Statale d'Arte per la Ceramica* in Faenza and is well-known for his sculptural works made from geometrically sawn refractories. The workshop 'proper' was cancelled about two weeks before I was to leave for Italy, but instead I was offered the opportunity to work in the studio each afternoon, when Galassi would be working there. In Italy the 'afternoon' commences at three o'clock after the siesta so that unfortunately it doesn't leave many hours each day in which to work.

My main aim was to test a number of clays with up to 30% added grog, or *chamotte* as it is called in Italy, slab-built pieces from each, and test fire them to see which would withstand raku firing without cracking. The clay and chamotte were mixed in a dough mixer which I thought was a wonderfully efficient machine, compared with a pug-mill, for mixing small amounts of clay. The Italian clay is quite unlike New Zealand clay in feel and texture, being much shorter and not so greasy. This was exemplified by their not wedging the clay, but by pulling 12 pound lumps of clay in half by brute force and then slamming them together, in order to mix and de-air the clay. Try doing that with SC 80!

The slabs were made in two ways — either by rolling out the clay on a fabric covered board (the fabric prevents the clay from sticking to the surface) or by cutting a series of slabs from a squared-up block of clay.

If the resulting slabs of clay were too small, two slab pieces were joined by butting them together, then by depressing with the thumbs firstly from one side of the join, then the other, the clay was welded together. By drawing a finger along the join the slabs were further welded together and a roll of clay pressed into the depression. This was then smoothed over with a square piece of flat steel, and the underside tidied up in a similar way. No slip or water was used in this process, as they can be the cause of uneven shrinking during drying, which can result in cracking.

To form the pots, the slabs were left in the sun for about 20 minutes, then cut to a pre-determined shape, the edges mitred and roughened by a *surform* blade. A small amount of slip called *barbitino* was used to make these joints. Barbitino is made from the body clay very slightly moistened with water worked into it until the clay becomes just sticky. The slabs were joined as described above, except that the point of a knife was used to weld the clay together. The pieces were made from slabs that had set sufficiently to be self-supporting, or inside a mould made from wood. A wooden mould can be made specifically for the form one has designed and will give a straight-sided, sharp-edged result. All of these forms and their joints in particular, survived the rigours of being raku-fired and, what to me is one of the ultimate tests, of being plunged sizzling into water after being briefly smoked in sawdust for 5-10 minutes.

While the larger pieces were drying, I made a number of small test tiles to try out different glaze effects and Italian glazes, but as these were from local factories they are of limited use in New Zealand. These were fired in a small home-built electric kiln with a chamber about 200mm square by 200mm deep. Galassi usually shows his students attending the workshop how to build these kilns, but I thought the electrical side was a little beyond me and my

Octagonal kiln at Galassi's studio, near Faenza.

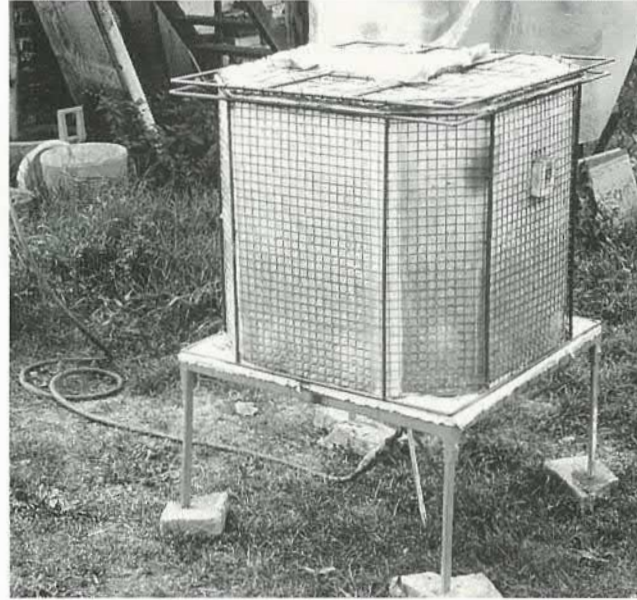

Circular raku kiln built in New Zealand.



## LIGHTWEIGHT RAKU KILN CONSTRUCTION: WIRE MESH ATTACHED TO AN OCTAGONAL STEEL FRAME.

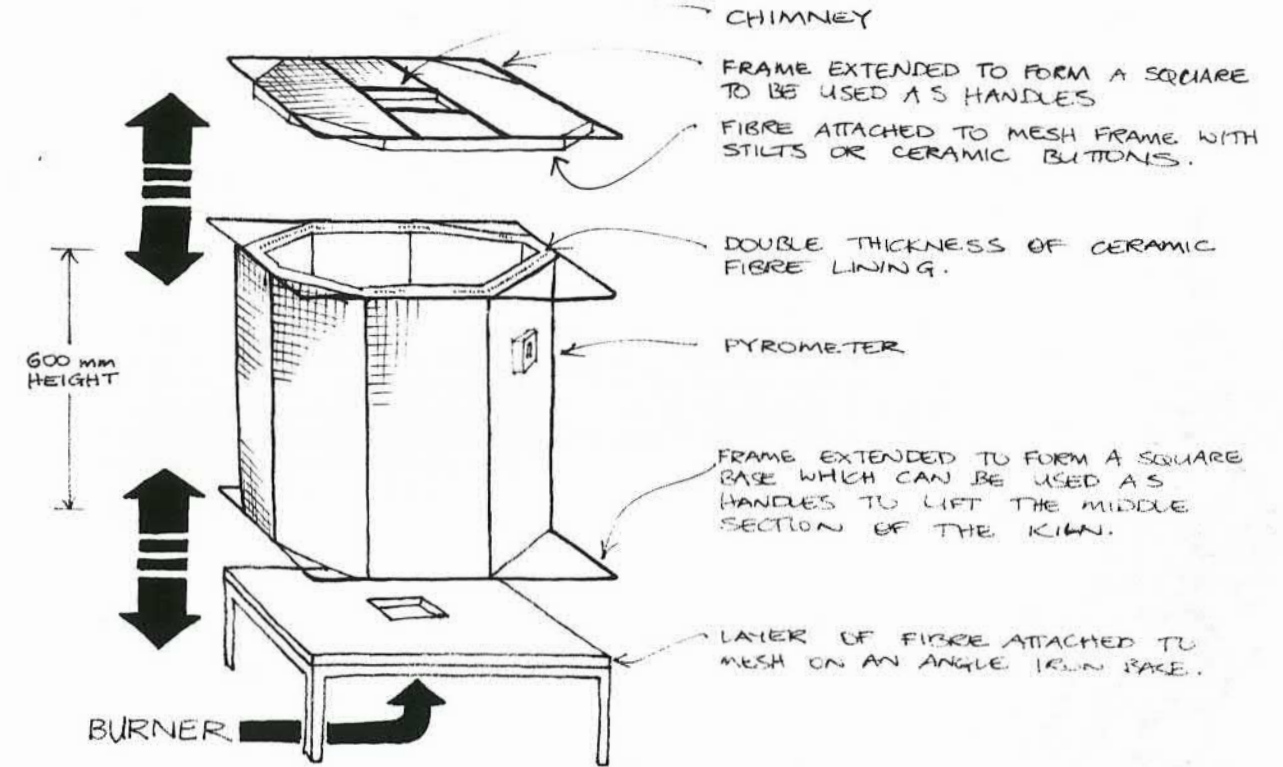

### CROSS-SECTION (LID)

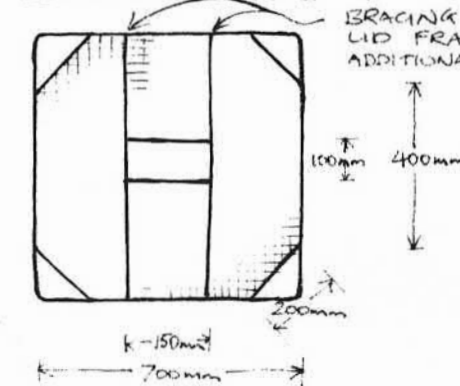

### DETAIL OF ATTACHING MESH TO FRAME

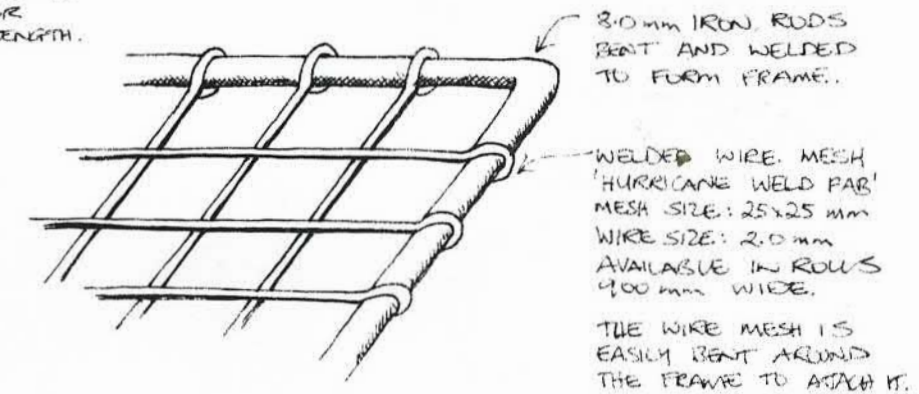

### SMALLER CIRCULAR RAKU KILN

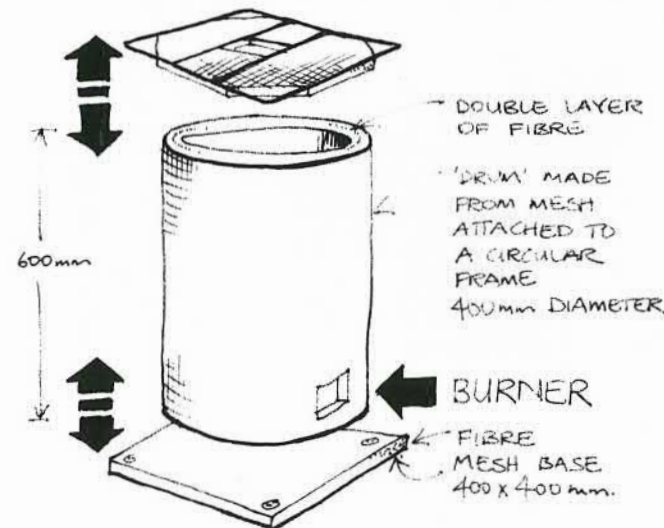

### WOOD-FIRED BLACK-FIRE KILN

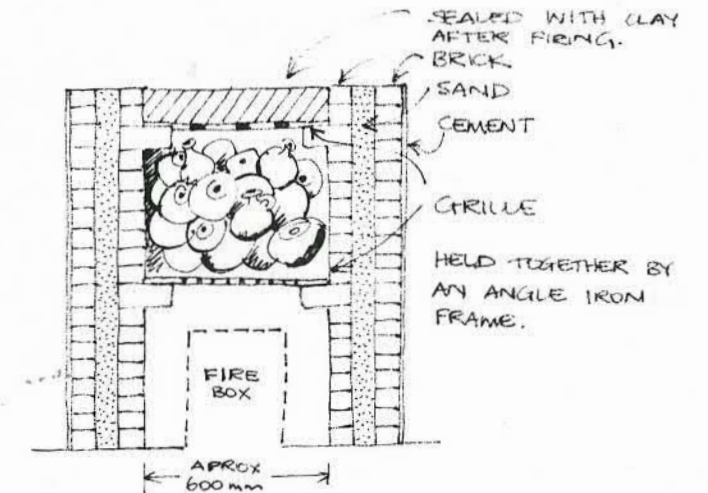

Diagrams and photos by Lynda Harris.



understanding of Italian. The kiln runs off a three-pin plug and took about one hour to heat up to 900°C with no temperature control, except to leave the lid slightly open. As we were to smoke the tiles in sawdust, I was quite amused to see the kiln being carefully carried outside when it was almost up to temperature so we wouldn't smoke out the studio — it was unplugged! The kiln was then reconnected and the firing continued. The pyrometer Galassi used had a metal probe and a digital hand-held meter, which meant that the probe could be used in a number of kilns without the risk of it breaking, as one has with a ceramic-covered probe. However, these are still relatively expensive.

The raku kiln in which we fired the larger pieces was constructed from a wire mesh attached to a steel frame as described in the accompanying diagrams. This kiln is very light for its size, easily shifted when required and flexible, in that each section can be separated. We had two shelves of pots, so when the pots were ready to be smoked, the lid was taken off and the first layer of pots removed. The heat was still retained in the lower shelf and when the main section was lifted off, these pots had not cooled too much.

Since returning to New Zealand I have made a smaller circular version which is more suited to the type of pots I make. I found the design was easy enough to build and its light weight a definite advantage after the drum kilns I have used previously. Cutting the wire mesh can be a vicious experience but I emerged relatively unscathed and without the loss of too much blood!

The diagram of the black-fire kiln I include for interest and because I am told it worked very well. This monumental kiln was built by a Spanish student during one of the summer workshops and it was easy to see why no smoke would dare escape through such massive walls. The dimensions are only approximate and unfortunately I only saw a video of the kiln being fired.

As I was only working in the afternoons I spent each

morning visiting the many galleries and museums in the area. I was fortunate that an exhibition of Persian maiolicas had just opened at the *Concorso*, along with a wonderful collection of Italian maiolicas and bright, bright maiolica sculptural pieces by artist **Ugo Nespolo**. Having been accustomed to travelling everywhere with a shoulderbag plus my camera, I was taken aback when directed by an armed guard inside the entrance to leave everything at the cloakroom, such was the level of security inside the exhibition halls. Although the international exhibition is now bi-annual, the committee also organises an alternative exhibition such as this, every other year in September.

Faenza is close to the historic centres of Ravenna and Bologna which are fascinating cities to visit. Ravenna is well-known for its mosaics which adorn many churches in the area, dating back to the 5th Century AD. The *Museo Archeologica*, right in the centre of Bologna, houses a wonderful collection of Villanovan and Etruscan ceramics and bronzes excavated from tombs in the area. Bologna is famous for the colonnaded streets that radiate out from the centre. A short way along one of these streets, the via San Vitale, is *Il Giardino dell'Arte*, a privately owned ceramics gallery. This gallery has works by many of Italy's leading ceramists and is probably one of the few galleries where one can see work of this standard, outside of exhibitions.

The workshops normally run for one or two weeks at various times over the summer catering for 10-12 students at a time. The atmosphere is relaxed and students can follow their own interests with guidance from Galassi and other local specialists whom he invites to give lectures. There are also visits to the local museum, ceramics school, galleries, factories and potters. Most of the students are from Europe and though the courses are advertised as multi-lingual, including English, their English was barely sufficient to teach effectively, so some knowledge of Italian is essential. ■

## WAIKATO POLYTECHNIC 1990 Students' Ceramics

Photos by student Kristina Ryan

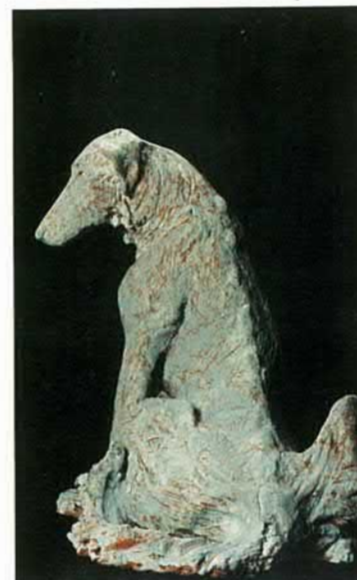

Cathy Thompson, 'Dog'



Debbie Powell, 'Pig' bowl



Cathy Thompson, 'Dog'



Glen Crossman, 'Angry Woman'



Jo Beckett, Garden Project



Martin Kelly, 'Boat Form'



Martin Kelly, double walled vessel



Michael Leach '4 Ever', Terracotta obelisk and tree forms.



Cathy Thompson, candlestick



Heather Bramwell, Cup Project



Carolyn Bowker, Cup Project



### 33rd NATIONAL EXHIBITION

& Elizabeth Lissaman,  
1920-1991

June 14 - July 14, 1991

The Bath-House Art and History  
Museum, Government Gardens,  
Rotorua, Ph (073) 485594

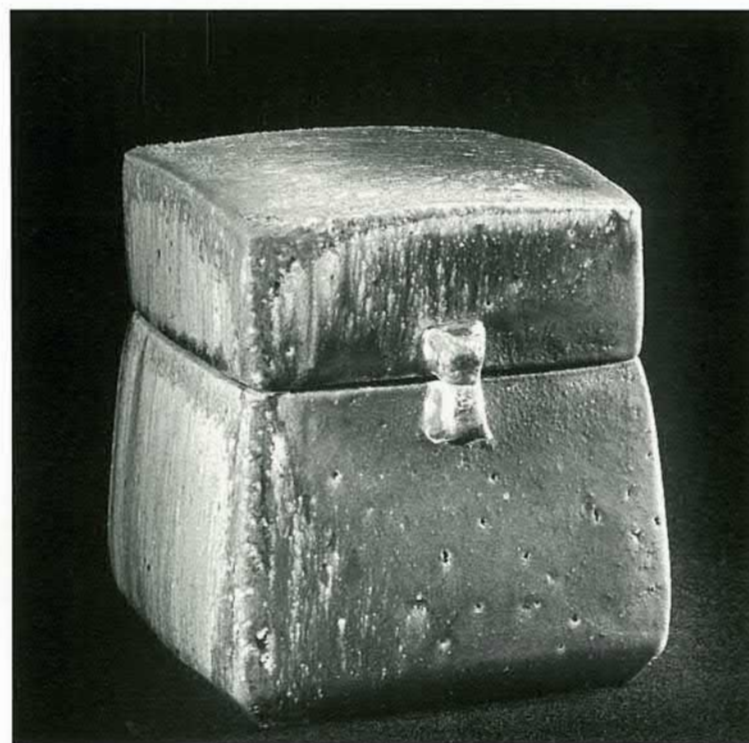

Photo: Bruce Martin, Anagama fired, from 32nd National Exhibition



# NEW FACES IN COROMANDEL

Howard S Williams, Albany

Photos by Howard Williams.

It seems as if the beautiful, tranquil Coromandel Peninsula has a history of rushes — the kauri logging rush, the gold rush, the annual tourist rush, the new mining and anti-mining rushes, the police helicopter weed-eradication rushes, and of course the quiet rush of potters, to and fro. At one time there must have been more potters per square Thames-to-Colville than the whole Nelson district, and that's saying something!

Through the seventies' summers, visiting potters poured in for the annual *Doos* at *Driving Creek*, one of the *PottyMeccas* of this species of craftsman, and one of the longest established potteries on the peninsula. Many others have come and gone, some casualties of tougher economic times (ruthless times, not Ruth-less though at least Roger-less) and some because the potters have done their green country thing and have reverted to city life.

Now there appears to be the start of another minor rush of a reverse sort: well-established city potters moving in to Coromandel permanently. I visited two such couples this January, both of them having the facilities to host paying guests in self-contained units, as well as their studios and direct-sales showrooms.

**Jenny and David Shearer** have been high profile potters in Wellington for many years, both serving on committees at local and national levels, exhibiting widely and sharing their expertise through teaching.

Now they are almost re-established in Oxford Terrace, just north of the top pub in Coromandel — still lots of landscaping to do outside, plastering and painting inside and planned extensions to the small showroom. The studio is working full time though and if the pots coming from the kiln are any indication, life here is very agreeable. Their own showroom is open most days, with many visitors during the summer season and Jenny is also a member of the 7 person co-operative which runs *True Colours*, a craft shop in a real old mining-town building in uptown Coromandel. Their studio is featured on a tourist Craft Trail map of the area.

Jenny and David know that the off-season will not be so good for their sales, though they say more visitors are coming all year round as people realise the peninsula is beautiful even if the sun isn't shining. They do keep in touch with their former selling venues and will have work regularly for the *Fletcher Challenge*, the *NZSP National* and the *Auckland Studio Potters* annual exhibitions. Jenny is planning an exhibition of pots and water-colours with **Wendy Masters** at *Villas Gallery*, Wellington in July.

They have not changed their pottery style much yet, because of the shift, using the same clay and the gas kiln brought from Wellington, but when things are fully bedded in they intend building a high firing, wood burning kiln, designed to fire terracotta at one end and porcelain at the other. New glazes have been developed and they are experimenting with using stoneware and porcelain clays together for different decorative effects. Developments in new glazes continue, with Jenny mostly throwing domesticware and decorative pieces, David with his slabbed pots and large free-brushed platters.

Besides the house (and swimming pool with rock water-cascade) and the studio and showroom, the 1 acre property has a self-contained cottage, fitted out like a motel unit with all amenities, to sleep four. It is available for rent — the phone number is 0843-58918.

Jenny Shearer



David Shearer



The Shearer's house



True Colours Craft Shop, Coromandel.



**Sally Vinson** and **John Taylor** are also very well known in the pottery world and have left the great *metrollops* of Auckland for an idyllic park-like 2½ acres in central Coromandel, which is probably why they have called it *Central Pottery*. This is in Charles Street — when you arrive in the township at the main T junction, turn left past the old fish and chip shop and immediately right before the town's lower pub.

Sally was trained as a potter in England and has for many years been New Zealand's foremost exponent of majolica type domesticware; thrown terracotta, or white earthenware with tin glaze over-decorated with brushed or sponge-stamped oxides, fired in electric kilns. She has always been active on committees for local pottery groups and served as president of the *NZSP* for 3 years.

For the last 3 years Sally was at *Carrington Polytech* as co-ordinator of the Craft Design course which she fully intended continuing for a further 3 years. However, she and John spent a summer holiday on their yacht, doing a wee drift around the Hauraki Gulf, called in at the Coromandel wharf at high tide, and as boat people are apt to do, strolled into town to buy a newspaper and fish and chips. An estate agent's window got in their way and they bought the property almost before the tide had turned. Back to Auckland to resign from their jobs — John was computerising for *Carter Holt* — and then they were suddenly building a new studio and showroom in their new garden.

*Carter Holt* assisted with a kitset building which John erected; *QE II Arts Council* assisted with a re-location grant which Sally demolished.

Sally used to be tied in to orders for specific pots from shops she supplied around the country. She now can make what she likes, as most of it sells readily from their own showroom, and she really enjoys the immediate feedback from the customer, an aspect not so often appreciated when retailers did her selling. She is using a lot of *Abbots* red clay, cobalt and copper for decorating and a new, more reliable white glaze.

John is developing his range of slab-rolled platters and slab-built pots using the same materials and firings. They take turns to serve in the showroom, depending on whose hands are most clay-free at the time and youngest son Jake assists when he is home weekends from school in Thames. The yacht gently rocks on a mooring not far down-habour.

The property is velvety flat lawn set with magnificent trees and ablaze with flower beds. The house is private from the studio and showroom, and nestled in trees to one side is a fully furnished cottage — complete with sets of Sally's pottery — which will sleep two or three people. It is available as a motel unit, for rent — the phone number is 0843-57171.

So now a new rush may begin, to visit old places and new faces in Coromandel. ■

The cottage in the Taylor's garden.



Sally and John Taylor, Jake and Lucy, on their showroom steps.



Sally Vinson overglaze decorating on majolica.





# THE COLLECTORS

Photos by Howard Williams

## Ron Sang

### Howard S Williams, Albany

I remember the heady days of the 1970s when Auckland still had **Tina Hoss** in *New Vision Gallery* and **Pete Sinclair** in *Alicat* and we all did the exhibition opening rounds early on Sunday evenings.

Often as not, on arriving at a particularly special exhibition, by a particularly special potter, I would meet, coming out already, **Margaret** and **Ron Sang**. It was not that they were cursory in their viewing of the exhibition — far from it. Ron just knew his pots and potters, knew what he wanted and made sure he got them — quick. I think he then used to leave, so he didn't have to explain to everyone why he had left behind such a sprinkling of red *sold* stickers!

Ron Sang is a well known partner in the architectural firm *Fairhead Sang Carnachan* of Newmarket, and although he was always interested in art as additions or visual modifiers of his buildings, he only bought his first pot in 1970 — a **Len Castle**. His interest in ceramics and sculpture was nurtured by his close relative, **Guy Ngan**, a noted sculptor and one time director of the *NZ Academy of Fine Arts*, Wellington.

From an initial excitement engendered by discovering what **Len Castle** was doing, Ron quickly became a discerning collector of ceramics, until they started to affect what he was doing in his designs for offices and homes. He began collecting paintings, prints, sculptures and ceramics to use as an integral part of his building designs, thus passing them on to his clients, educating many of them along the way into becoming collectors themselves.

Ron bought at exhibitions not only for himself, but also with the thought in mind of where he could place some of these pieces in future commissions. So he bought on a multi scale. Something else then happened — he realised what an increased visual impact multiple pots as a series, had on a display shelf, compared with a single pot — and this effect could be further enhanced by backing the shelf with a mirror to double the image. The pots he chooses lend themselves to this treatment as they are usually very pure in line and form, and rich to startling in colour. He doesn't like "wonky" pots.

A major ingredient of Ron Sang's design philosophy is to keep his buildings' interiors simple, and clean almost to the point of clinical — they can then be warmed, humanised, softened, enriched by judicious placing of good art work. It gives his work a very special Sang signature, educates and enthralled many of his clients, puts him on the invitation lists of all galleries, and has helped the careers of some of our best artists.

As a mural maker I once complained to Ron that a commissioned ceramic panel I was making for another architect, for which I was contracted to receive \$5,000, was going on a wall of imported black marble. The area of marble covered permanently by my panel was worth \$5,000. He replied that this was an aspect he always considered in his work and wherever possible he designated simple local materials, even just plaster board for walls, allowing more funding to be allocated to art work. "Art work is the icing on the cake. Remove it and my work looks bland, unfinished."

So Ron Sang is not just a collector, but a patron of the arts

and a supporter of artists. Although he will guide his clients as to the buying of art works for their buildings and is not reticent to include the financial investment aspect, he has no concern for this in his personal buying philosophy. The monetary angle is not considered — he buys purely for his own aesthetic satisfaction, making his collection one of a narrow spectrum of artists. He often commissions work from these as well as purchasing from exhibitions. Small works he buys as gifts for clients and the many visitors his firm entertains.

On a trip to another city he will take many days more than is really needed for his business requirements — he has to see all the potters and painters he knows in that area while he is there. Overseas trips become major exercises as he fills his bags with special small ceramics as gifts for hosts and business contacts.

Many important design awards have been won by Ron Sang's buildings and this has partly been due to his integral interior design concepts. His own home is an excellent example, pure white walls with no skirtings or scotias, soft blue-grey woollen carpet and chrome with black leather furniture, lots of special lighting.

Powerful colour is introduced by massed works by artists like **Rodney Fumpston**, **Don Binney**, **Gretchen Albrecht**, **Philippa Blair**, **Brent Wong** and **Peter Sidell**. Ceramics from **Len Castle**, **Graeme Storm**, **Margaret Milne**, **Beverley Luxton**, **John Parker**, **Rosemary McClay**, **Nick Brandon** and others. Fibre hangings, wood and metal sculptures — an exquisite, but very liveable art gallery home.



Ray Rogers in the corridor



Nick Brandon on the sundeck



Shelves of John Parker



Keith Blight, Lawrence Ewing and Nick Brandon



Graeme Storm in the dining room



Margaret Milne on the dining table



Barry Brickell engine terracottas in the garden



Roy Cowan in the swimming pool



# BOOKS

Reviewed by  
Howard S Williams

**THE COMPLETE POTTER** is a new series of books designed to teach and inspire. In each volume, four to date, a leading potter examines the fundamentals of a specific pottery skill. The volumes all have a similar layout and style, starting with chapters on the history of the particular subject, then referring to basic techniques, equipment and materials. New design directions and technical refinements are explored for the more experienced potter, and there are many diagrams, recipes for clay bodies and glazes, and handy working hints. There are colour photos of work from past and contemporary potters who are known for their contribution to that particular part of the pottery field.

The series is edited by **Emmanuel Cooper** of England, who is well known not only for his pottery and writing skills, but also for his many years as a joint editor of *CERAMIC REVIEW*. The series is published by *Kangaroo Press* of NSW, Australia at a NZ retail price of \$39.95 (GST incl) per volume. They are all hardback and have 96 pages with around 50 to 70 illustrations.

**SLIPS AND SLIPWARE** by **Anthony Phillips**, who is obviously an excellent maker and decorator of slipware, judging by the photos of his own work. The volume is a little strange in that it gives very few credits for the photographs, other than those historical ones from the *British Museum* and the *Fitzwilliam Museum* and other such collections. The photos are mainly excellent, especially the black and white instructional series. One colour plate is an unfortunate *OOF* (out-of-focus) showing a bowl by **Sheila Casson**, while a semi-*OOF* blurs a vase by **Fiona Salazar**. These are a shame as the rest of the colour plates are of a high standard, showing work from 11 potters.

The book takes one through a wide range of slip techniques, giving good working advice as well as technical data — preparation of slips, proven recipes from English contemporary potters; terra sigillata; colouration, oxides, stains and their testing; decorating, dipping, pouring, brushing, spraying; slip-trailing; resist and stencilling; scraffito, feathering, applique, marbling and inlay. There are glaze recipes, a section on kilns and firing and a bibliography rounds it off. A good book for learning and teaching about slipware.

**HAND BUILT CERAMICS** by **Jane Waller** who makes excellent pots by a wide range of techniques, though they are all basically built by hand. She gives an interesting early chapter on sources of inspiration and aesthetics and how they can be utilised, for people who cannot keep their hands out of clay. Generally the photos are excellent, though again there are not many credits and there is one *OOF* — a vase, like in the previous case, by **Fiona Salazar**!

Chapters deal with clays; pinching, coiling, slabbing, press-moulding; texture, coloured clays, layering and some glazes. It may sound pretty basic described as briefly as this, but there is a great deal of information and inspiration to be gained from this volume.

**RAKU**, by **Ian Buyers**. This volume also has many excellent photos some of which are not credited with the photographer's name. Maybe it is a small point, but as a potter and a photographer of pots, I am disappointed when both contributing artists are not given credit for the photographic presentation of a pot. The *OOF* in this volume is a poor illustration of *The work is removed with tongs* which doesn't really show the tongs or how the work is being removed from where. The 'work' looks as if the *OOF* potter is carrying it precariously on gloved fists.

The rest of the photos however, are good, as is the writing which gives detailed descriptions of what raku was, and what it has become — its problems and potentials, its materials and making processes. There is a clear explanation of how to make glaze crayons for drawing decorations and many plans and diagrams to help the readers build the type of raku kiln most suited to their needs. There are recipes for raku clays, colourants, glazes and stains, lustres and textures and a chapter on personal approaches and philosophies from some nine contemporary raku potters. An excellent raku book.

**ANIMAL FORMS and FIGURES**, by **Rosemary Wren**. This book is special for me as I have an example of a wren made by Rosemary Wren about 1962, at which time I had explained to me her technique of modelling animals by using coils flattened, flanged and shaped. Here this technique is fully described with clear diagrams — a must for any potter wanting to hollow model large animal forms.

The author's ability to abstract the essential personality of her subjects is fascinating and she describes how this is done — with patient observation, familiarisation and many quick

sketches. The fact that the majority of bird or animal models one sees constructed in clay are nothing more than twee ornaments, indicates that this volume should be required reading for anyone working, or playing in this area of ceramics. Dragon making is not included, thank goodness.

Human figure modelling is also discussed and illustrated — there isn't a single *OOF* in this volume — and the sketches by various artists are delightful. The personal approaches of 12 other potter/artist/sculptors are given including **Peter Crotty** who has worked with Rosemary Wren since the early 70s.

Apart from the technical aspects gained, this book is eminently readable.

All four volumes have lists of suppliers of materials and periodicals and they are well designed and laid out, making for a very collectable series. Titles to be added this year include *Pots for Plants and Gardens*, by **John Huggins** and *Working with Lustres* by **Margery Clinton**.

Two other books published by *Kangaroo Press*, but not in the same series, are *Lustre for China Painters and Potters*, by **Heather Taylor** (\$26.95) and *Magic on Glass* by **Birthe Hattel** (\$39.93). The English, from Danish, text is by **Ian Cocker**.

Both these books have a wealth of information on techniques, materials and processes, but it is interesting they display *Hobby Ceramic* aesthetics, the step-by-step, how-to-do-it attitudes of people who decorate other people's, or even factory-made forms.

Some examples are interesting and show there is a great potential for creative work to be done using these techniques, but most are boringly decorative pieces which I might describe as dressing-table ornaments. Those whose cultural experience or education allow them to enjoy this type of art work may well feel I am 'putting it down'. Those who know what I mean, know exactly what I mean.

Both books are beautifully produced and illustrated and are good technical manuals for the processes they describe. They are worth buying for this information, as long as the prospective artist can bypass the designs shown to produce something more real to themselves in the truly creative sense. ■

New Zealand retailers of these books may be found through the importing agents:

**Randy Horwood Ltd**  
PO Box 100-055  
North Shore Mail Centre  
Auckland

# MAU MAHARA

## Our Stories in Craft

Photos by Deborah Smith

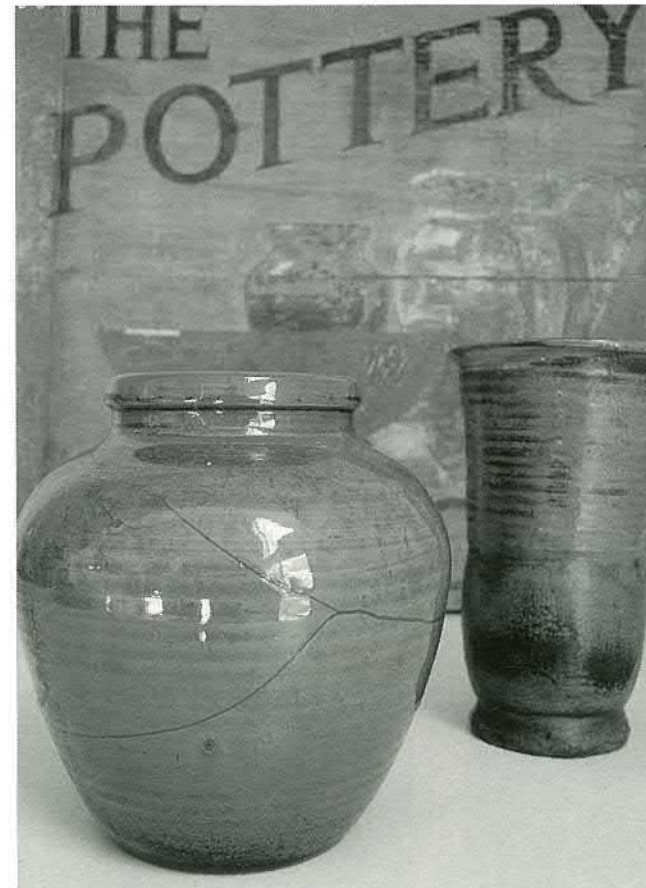

Pots made, (from top, Elizabeth Matheson, Briar Gardener and Olive Jones) for the 1939-1940 NZ Centennial Exhibition.

Olive Jones' pottery studio sign with a selection of her work, after 1934.

The *Crafts Council of New Zealand* has put together this unique travelling exhibition which is based on stories — the stories involved with our crafts and the people who created them and these stories.

Craft objects can become family heirlooms because of their association with the history of people in the family — grandad's walking stick, a quilt made by great-grandma, special things the kids made at school as presents for mum, photo albums recording the family history, craft objects of the past which tell us something of how our forebears lived, how they decorated their lives.

These craft objects trigger emotions linking us with our past, telling us stories about who we are and where we have come from. They have an important place in the psychological

make up of any society.

*Mau Mahara — Our Stories in Craft* brings together such fragments of our society in a celebration of the *Crafts Council's* 25th year of operation, and as part of the 1990 commemorations. As the council's president **John Scott** writes "This exhibition was conceived to pay tribute to the energies that have shaped New Zealand crafts.

A beautifully illustrated book on the exhibition has been published by *Random Century*, with photographs by **Deborah Smith**. The major sponsor for the exhibition is the *Ford Motor Company*.

This exhibition was co-ordinated as a 1990 project by **Jim and Mary Barr**, freelance exhibition organisers and art consultants. Jim was director of the *Dowse Art Museum* until 1981 and has been responsible for many craft

exhibitions.

The project commissioners were **Justine Olsen**, curator of Applied Arts at *Auckland War Memorial Museum*; **John Parker**, well known potter, designer of exhibitions, theatre sets and costumes, and *METRO* magazine's film review columnist; and **Cliff Whiting**, chairman of *Te Waka Toi — the Maori and South Pacific Arts Council*, teacher of art and practising painter, carver, printmaker, illustrator and photographer.

The exhibition has already shown in Wellington at the *National Art Gallery's Shed 11*, and in Auckland at the *War Memorial Museum*. It will be showing in Christchurch at the *Robert McDougall Art Gallery* from May 4 — June 23, and in Dunedin at the *Otago Museum* from July 20 — September 1. ■



# CRAFT POTTERS NELSON INCORPORATED

Photos by Bob Heatherbell.

## 17th Annual Exhibition

Nelson's oldest potters' workshop group continues to contribute to the Nelson pottery scene, as it has done now for many years. Many of its members have gone on to become professionals, but have retained their links with the group.

This 1990 exhibition, held last

August in the group's excellent facilities, has maintained its interest and popular appeal. The exhibition opening is always a social event attended and enjoyed by potters and guests from around the district. The official opening for the 17th Annual Exhibition was by MP Ken Shirley.

Guest potters this year were **Anne Powell** from Hunterville and **David Atkinson** from Weston, North Otago. Apart from work from the group itself a large number of local potters supported the exhibition with entries, making an excellent showcase of current work from the region. ■



David Atkinson. Earthenware baskets.



David Atkinson. "Bottles" earthenware.

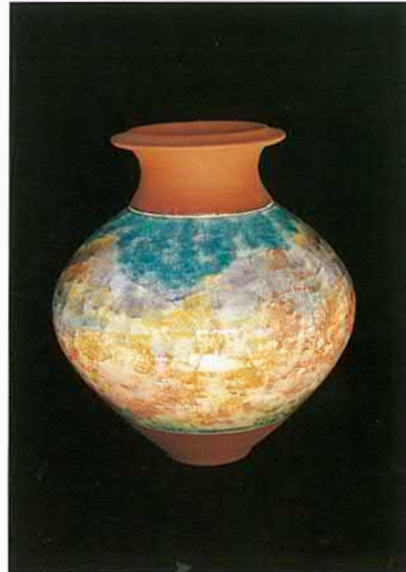

David Atkinson. Earthenware jar.



Royce McGlashen. "Starry, Starry Night".



Jane McCallum. Platter.



Anne Powell. "Kowhaiwhai" carved vessel.



Julie Warren. "Tea Set".

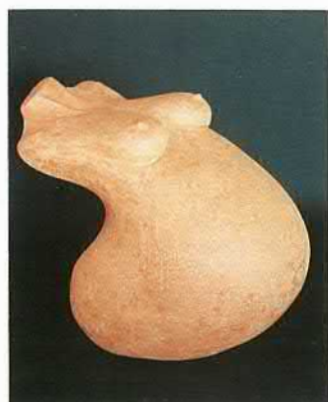

Erika Aupperle. "Pregnant".



Anne Powell. "Fumed Nesting Vessels".

# The key to success in ceramics isn't just anybody's gas.

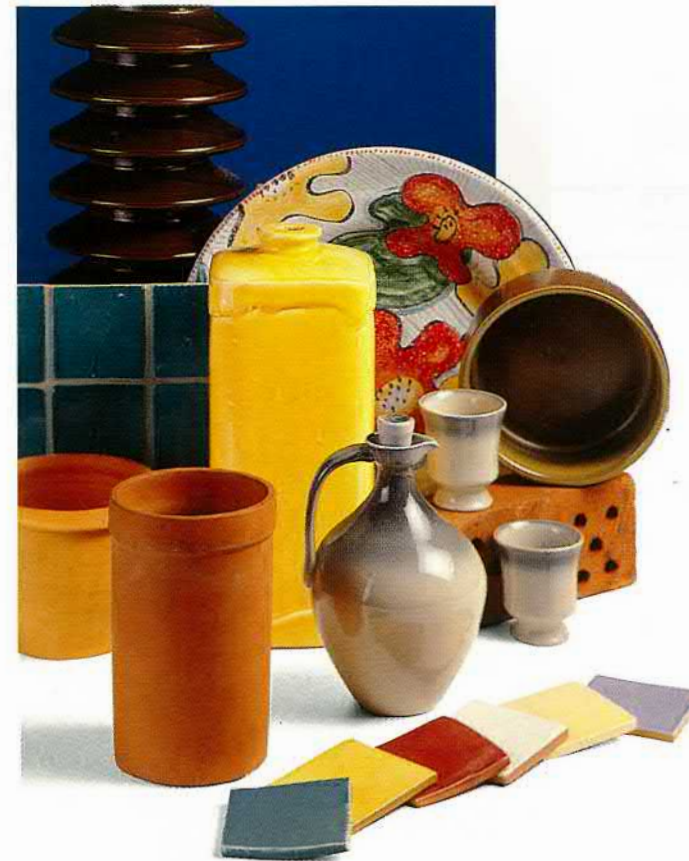

Producers of quality ceramic products often find that a lot of energy sources just don't stack up.

The ceramic producers standards are tight. Success requires a strong, concentrated heat source and instant control.

As with any business, the bottom line is vital. Cost efficiency is paramount.

The answer lies right there on a plate. BP Supergas LPG. Available in ready supply, everywhere.

Eliminate energy problems. Increase the payoffs. For more information about BP Supergas LPG, phone us toll-free on 0800 800 574 and speak to the experts.

**BP Gas**  
The LPG Authority





# LA BORNE EN FEU

John Lawrence, Dannevirke

After some 12 months of armchair travelling and listening to French tapes, the idea evolved of blowing my life insurance on a 'ceramic crawl' of the United Kingdom and France.

We were particularly interested in La Borne and its surrounding area. When we arrived in London in July we saw a tiny announcement in *Ceramic Review*, that the 3rd International Symposium of Potters, entitled *La Borne en Feu* was to be held the next week.

La Borne is a small village in France where most of the inhabitants are potters, retired potters, or are engaged in the craft in some capacity. It is situated in a vast forest area with extensive deposits of clays. A huge wood-fired stoneware industry covering the whole region dates back as far as 1250AD, with even some shards of Roman origin being found. From the 17th century until the Second World War numerous families in La Borne depended on the making of such items as salting pots, milk jugs and oil pots for a living, using very big Anagama type, wood-fired kilns of some 20 to 50 cubic metres.

After the war, new artist potters of different nationalities arrived, and consequently new techniques and outlooks, but nearly all having wood-firing as a common bond.

At the symposium there were 23 wood kilns firing simultaneously in workshops in different parts of the village. These ranged from an American kiln of 8 cubic metres to the La Borne traditional kiln of 25 cubic metres which took seven days to reach 1280 to 1300°C.

While the kilns were being fired by relays of potters, there were lectures, demonstrations and videos, as well as the equally important communal eating, drinking, socialising — and Jazz! There were also large numbers of small children and french dogs to complete the scene.

Around nearly every house in the village were collections of big pots, old and new, planted with masses of flowering plants. Against nearly every wall were huge stacks of kiln wood, mostly oak, all split with the famous hoe-shaped La Borne adze.

The first person we met on arriving at La Borne was English potter and editor of *Pottery Quarterly*, **Murray Fieldhouse** who, in between numerous anecdotes gave us a lot of valuable information.

On two floors of the old schoolhouse, called *The Home of the Potters*, was staged a pottery exhibition of work from most of the potters attending the symposium. This included not only potters of different nationalities living in the area, but also invited potters from all over Europe and as far afield as Australia — though not New Zealand.

At this exhibition was a wide scope of work; the fine porcelain of **Gwyn Piggot** (Australia), the massive platters, unglazed and polished after firing of **Jacques Kaufman** (French Swiss), the very lively raw-fired earthenware sculptures of **Gerard Lachens** (France) and huge garden pots made by many of the potters in the La Borne tradition. For me the highlight was the work of a La Borne potter called **Astoul** who made simple classical shapes, beaten and impressed with stamps and left to be glazed by the kiln.

Another exhibition is a permanent one installed in the ancient deconsecrated chapel at La Borne. Historical and technical pottery displays trace the development of the area and look very effective against the walls of the old chapel. There are also continuous videos of pottery making and firing, both past and present.

The La Borne symposium finished with a two day market covering about two acres, with potters coming from as far afield as Marseilles. It had been cold and damp most of the week, but at this market it rained so heavily that potters spent a lot of time emptying rainwater out of their pots. It was particularly sad to note that the month following was the hottest on record in France.

If anyone reading this is considering such a trip, we would be pleased to give advice and information. ■

At La Borne, a three-chamber climbing Japanese kiln, 6 cubic metres, built by potters Dominique Garet and Janet Stedman.

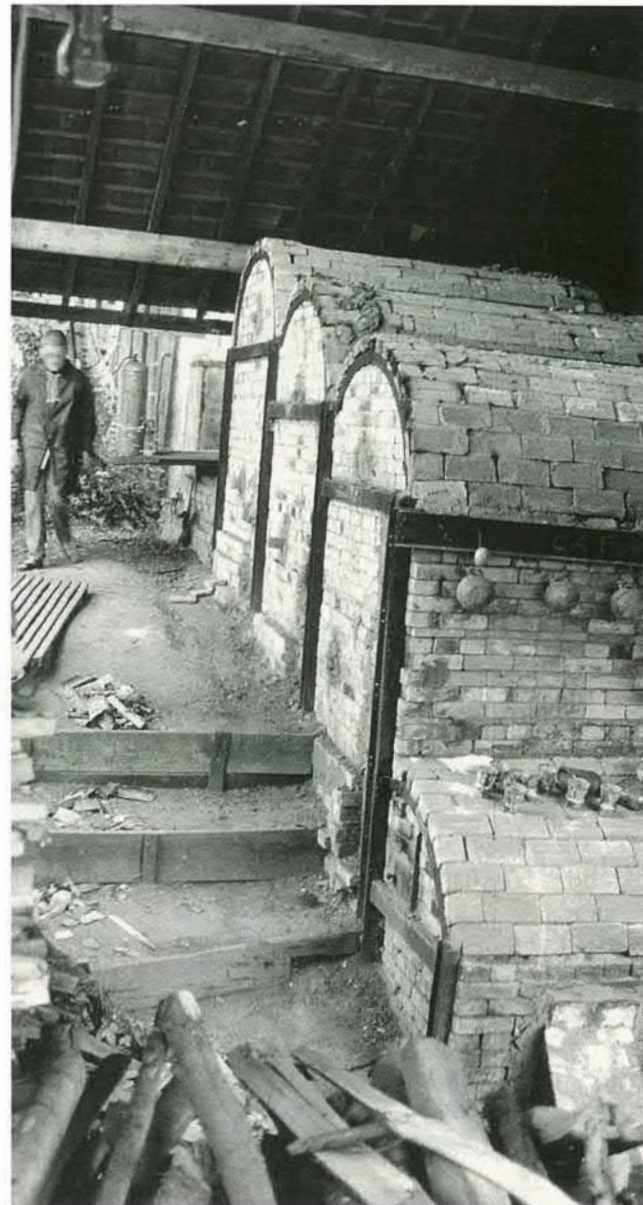

La Borne traditional wood-fired kiln. 25 cubic metres. This kiln was constructed at the end of 1800 and had been unused for many years until it was restored by the potters of La Borne. It was first fired again in 1977.

The rear of La Borne traditional kiln. There is no chimney — the flue exit is the lower half of the wall. During the final part of the firings a huge flame comes from this flue, covering the adjacent roadway and making it impossible to pass. After each firing the wall above the flue is dismantled to unload the pots and to pack the kiln again.

## WESTERN POTTERS SUPPLIES (1986) LTD

Our Auckland shop has **MOVED** to a **NEW CENTRAL ADDRESS**

**Unit 4 / 43a LINWOOD AVE  
MT ALBERT. Ph: 815-1513**

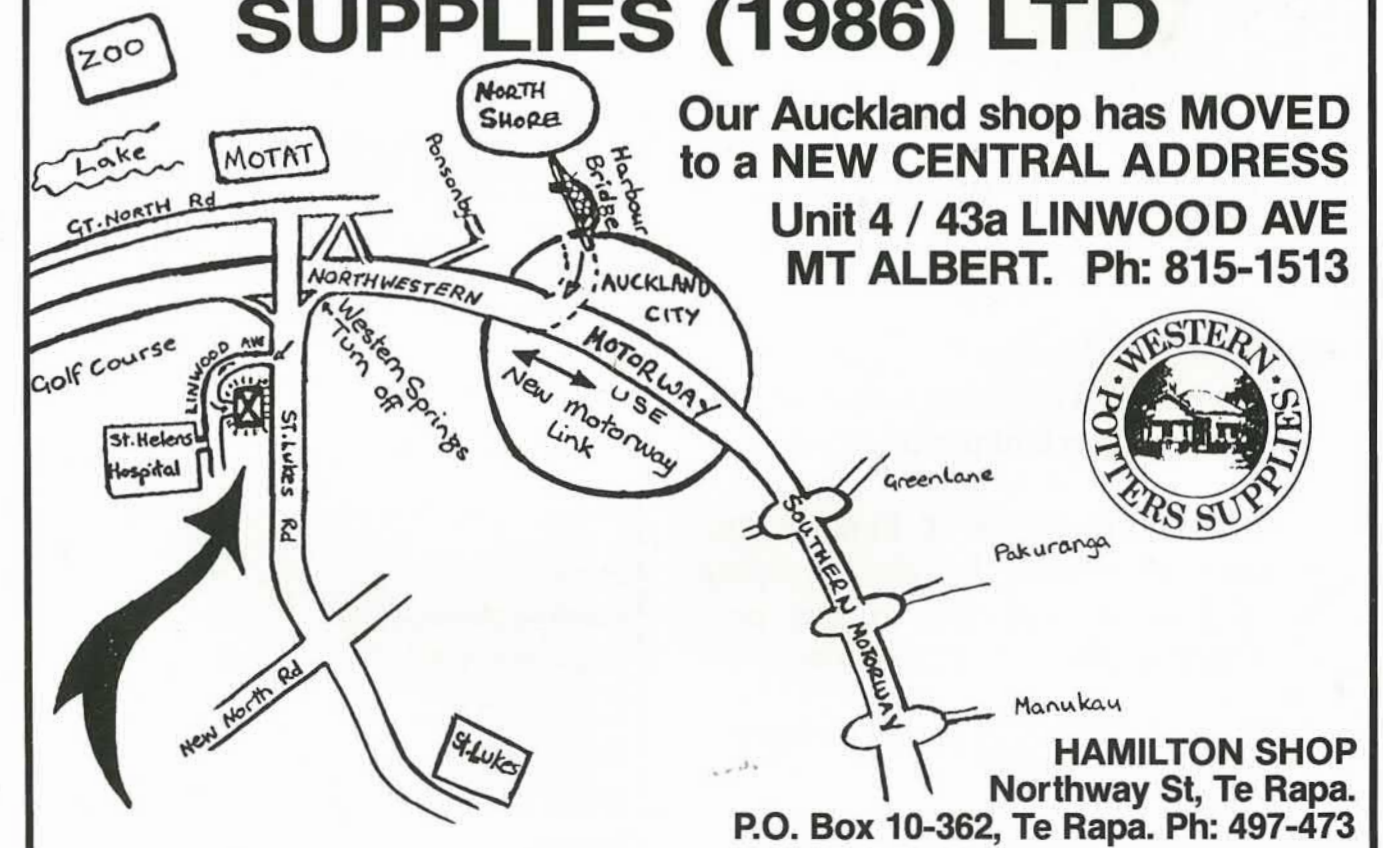

**HAMILTON SHOP**  
Northway St, Te Rapa.  
P.O. Box 10-362, Te Rapa. Ph: 497-473



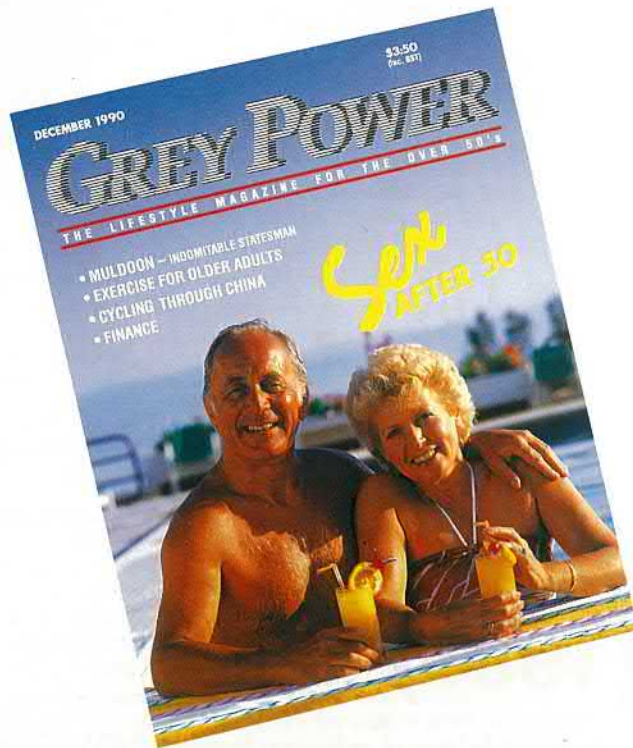

## GREYPOWER magazine

will lead you through the practicalities and excitements of all facets of this new, supremely important period of your life.

From the intricacies of Finance, the pleasures of Travel, the fun of keeping Fit, to how to really live in style pre-retirement and during retirement.

**SUBSCRIBE NOW!**

### SUBSCRIPTION COUPON

To  
**The GREY POWER PUBLISHING CO. LTD.**  
 P.O. BOX 99769, Newmarket, Auckland  
 I wish to subscribe to "Grey Power" magazine  
 as indicated below

1 Year subscription – 6 issues \$35

2 Years subscription – 12 issues \$65

Subscription cost includes GST, Postage and  
 a Directory after 12 months.

Mr/Mrs/Ms.....

Address .....

Phone.....Age.....

I enclose cheque/Money Order for \$.....

Please charge \$.....to my credit card

Amex  Visa  Mastercard

No

Expiry Date...../...../.....

Signed.....

### SUBSCRIPTION COUPON

To  
**The GREY POWER PUBLISHING CO. LTD.**  
 P.O. BOX 99769, Newmarket, Auckland  
 I wish to subscribe to "Grey Power" magazine  
 as indicated below

1 Year subscription – 6 issues \$35

2 Years subscription – 12 issues \$65

Subscription cost includes GST, Postage and  
 a Directory after 12 months.

Mr/Mrs/Ms.....

Address .....

Phone.....Age.....

I enclose cheque/Money Order for \$.....

Please charge \$.....to my credit card

Amex  Visa  Mastercard

No

Expiry Date...../...../.....

Signed.....

## RECENTLY SEEN

Ann Clifford, Dunedin was awarded an Honorary Degree for her contribution to the 3rd World Triennial of Small Ceramics held in Zagreb, Yugoslavia in November 1990. She won the same award in 1987. Her latest work was 'The Observers' a porcelain sculpture 5x9cm, based originally on sea-life forms.



Paul Winspear, 'Ka'va Bowl'



Barry Hughes, 'Fishing'

Waikato Society of Potters

Photos by David Cook



Cathy Thompson



Anna-Marie Klausen



Libby Boyd

NZ Academy of Fine Arts, Wellington



**NEW ZEALAND'S  
COMPLETE SUPPLIER**

KILNS  
CLAY  
GLAZES AND MATERIALS  
BULK SUPPLIES  
KILN FURNITURE  
WHEELS

AIR BRUSHES  
SPRAY GUNS  
COMPRESSORS  
LOW FIRE GLAZES  
ONGLAZES  
LUSTRES  
STAINS

CHINA  
PAINTING  
SUPPLIES

POTTERY CRAFTS  
HARRISON BELL  
DEGUSSA

agents  
for

**Cobcraft**



PRICE LIST & CATALOGUE  
MAIL ORDER THROUGHOUT NZ  
Cobcraft Potters Supplies Ltd.  
24 Essex St  
P.O. Box 32024  
Christchurch

Ph. (03) 667-229



EST. 1987

Manufacturers of Quality Clay

\$400 per tonne incl GST

Business (03) 614-7751  
Richard O'Leary  
A.H. (03) 614-7577

(Winchester — Hanging Rock Road)  
R.D.12, Pleasant Point, New Zealand

Bernies Clay is a recently established business situated  
on a large natural deposit of raw clay.

Our aims are to produce a quality product and maintain  
a constant supply for many years to come.

All Enquiries Welcome

the electric furnace co ltd

**elec furn**®

- ★ Industrial & Hobby Kiln & Furnace Manufacturer
- ★ Gas and Electric
- ★ Top or Front Loading — Top Hat or Truck Kilns
- ★ Using only Imported Refractories (no cheap substitutes)
- ★ One Year Unconditional Guarantee
- ★ Sigma Temperature Controller & Programmers
- ★ **Elements the latest breakthrough.** Three to four times or longer element life. No sagging — or growing. **FIRST IN NEW ZEALAND.**
- ★ Spares for any type or make of kiln. Service NZ wide.

**THE ELECTRIC FURNACE CO. LTD**  
73 Wiri Station Road, Manukau City, Auckland 6  
Phone: (09) 263-8026. Fax: (09) 277-7481  
P.O. Box 76162, Manukau City, Auckland.



**The Dowse Art Museum**

collects the fine arts in materials traditionally associated with the crafts.

**Art Museum hours**

Monday to Friday 10am — 4pm  
Saturday, Sunday and public holidays  
11am — 5pm

**Lower Hutt City Centre**  
Dowse Museum (04) 695-743



**ANNUAL  
CONTEMPORARY  
CRAFT COMPETITION**

**1991: Ceramics**

August 4th-17th  
Selected and judged by  
Vincent McGrath, Tasmania

Further details from the sponsor:-  
Compendium Gallery  
49 Victoria Road  
Devonport, Auckland 9.  
Telephone: 445 1577

**Randy Horwood Ltd**

Lustre	\$26.95
Magic on Glass	\$39.95
Animal Forms	\$39.95
Handbuilt Ceramics	\$39.95
Slip and Slipware	\$39.95
Raku	\$39.95

Available from all good booksellers, or:

**Randy Horwood Ltd**  
P.O. Box 100-055, North Shore Mail Centre  
Glenfield, Auckland  
Phone 444-2373 Fax 443-0735



**MAC'S MUD CO**



- PLANTERBODY (terracotta) Plastic easy to throw, good for planters and domestic terracotta. Orange Cone 03—Cone 01 Red.
- REDWOOD Grey/Brown plastic stoneware. Cone 9—10.
- WAIWHERO Light coloured stoneware, good for salt glazing. Cone 9—10.
- WHITESTONEWARE Very plastic dense whitestoneware. Cone 10—11.
- WHITESTONEWARE T Very plastic dense whitestoneware, good for oxidized firing. Cone 9—10.
- WHITESLABWARE Coarse whitestoneware, good for slabs and handbuilding. Cone 9—11.

All above clays \$440 per tonne incl. GST ex factory.  
Good freight rates available.

PORCELAIN Very fine, translucent, white.  
\$32 per 20 kg bag. \$8 per 4 kg pack.

**Royce McGlashen**  
128 ELLIS ST, BRIGHTWATER, N.Z.  
TELEPHONE (054) 23585



# PREMIER CERAMIC AWARD

## OTAGO PENINSULA TRUST

The Otago Peninsula Trust is thrilled to host the first Cleveland Charitable Foundation Trust Award for Ceramics.

The Otago Peninsula Trust, together with the Cleveland Charitable Foundation Trust announces a premier award of \$2,000 for the outstanding ceramics entry in an exhibition to be staged at Glenfalloch Gardens Chalet, Dunedin between 9-18 August this year.

This award is open to all potters resident in New Zealand. Each entrant is invited to submit one work for this award, but the work must not have been created under the guidance of a tutor. There is no category or theme and the only criterion for judging will be the standard of conception and excellent of execution.

The judge will be a person of high repute in the field of ceramics, who will choose from the entries a selection of works to be exhibited. All works must be available for sale.

Glenfalloch Woodlands Gardens is the home of a potters' group which enjoys the use of a small cottage set deep in a valley by a stream. This group of enthusiasts has over many years staged ceramics exhibitions in conjunction with the Otago Peninsula Trust. To stage this exciting display of work from New Zealand's best ceramic artists will indeed be a challenge.

Dunedin has long been noted for its natural beauty and the rich heritage of buildings and gardens left by previous generations. This concentration of attractions is now gaining extra attention from tourists. An outstanding example is the peaceful and interesting harbourside property, Glenfalloch.

Glenfalloch, Gaelic for Hidden Valley, was named by George Grey Russell when he bought the 30 acres in 1871 to build his fine gentleman's residence known as The Homestead. The extensive garden with its mixture of native and exotic trees and notable collection of rhododendrons and azaleas has been developed over the years.

The Potters' Cottage.

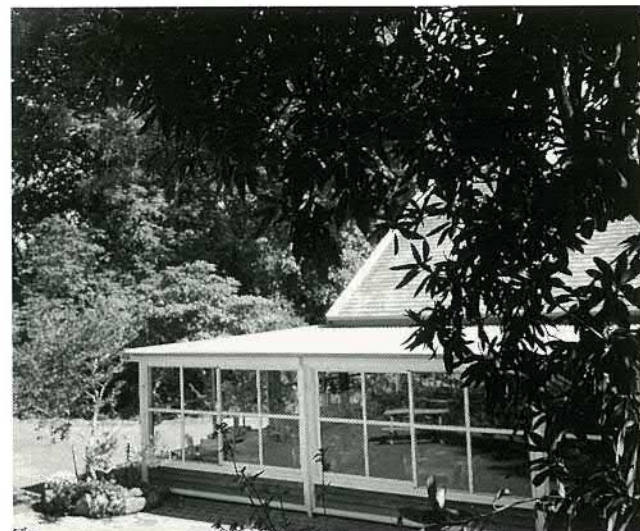

The Chalet from the gardens.

The property was bought by the Otago Peninsula Trust in 1968. The woodland garden is unique in Dunedin's heritage and an irreplaceable asset cherished for the enjoyment of Dunedin people and visitors. Two years ago the Otago Peninsula Trust completed the Wilson Neil Chalet, a building nestling within the gardens, used for dining to promote the gardens and to provide a facility to enhance Glenfalloch. It functions as a top flight restaurant serving both locals and visitors. The chalet, an open plan design with windows facing three sides to provide natural light and superb vistas of the garden, is an excellent venue for displays and exhibitions.

The Royal Albatross colony at Taiaroa Heads is the only place in the world where these great birds nest close to civilisation. Managing the visitors viewing is another responsibility of the Otago Peninsula Trust.

The Otago Peninsula Trust is very grateful to the Cleveland Charitable Foundation Trust and to Les Cleveland for endowing this biennial award. Les has had a long association with the Trust, latterly as a member of the Board of Trustees. He has a very wide knowledge of conservation issues in Otago and a sound horticultural understanding of Glenfalloch. He is a noted baritone and theatrical performer with a great love of the arts, and has established the Foundation to provide funds to help the performing and visual arts and conservation, mainly in the Otago-Southland area. Several artists and conservationists have been able to further their studies and contribute in their fields through the generosity of the Foundation. ■

Entry forms and further information may be obtained from:  
**Cleveland Ceramics Award**  
**Otago Peninsula Trust**  
**PO Box 492**  
**Dunedin**  
**Ph: (03) 466-7351**

# BONSAI

Robyn Morris, Tasmania

This article written by Robyn Morris with the assistance of Elizabeth Simeonoff, tutor at the Ryde School of Bonsai, was first published in the Tasmanian Potters Society newsletter.

Literally translated *Bonsai* means 'planted in a tray'. These miniature replicas of trees and plants cultivated in shallow containers, though small in size, express the beauty of trees in a natural environment.

Early Japanese records from the Kamakura period (1192-1333) in pictorial scroll form, show little trees planted in ceramic basins displayed on shelves in the background — and these scenes depict life some hundreds of years earlier!

In China and Japan much-prized examples of this art may be found which are well over 100 years old. Bonsai are handed down from father to son for generations. The tender care necessary to maintain strong healthy plant life to such a ripe old age must surely dispel the notion that Bonsai practices are 'cruel' — they usually get more attention than the rest of one's garden! Their cultivation is quite fascinating and can become almost addictive.

The harmony between pot and tree is important. Having just the right container for the plant can 'make' the setting. Ideally when shown to the public the pot should go unnoticed and the tree attract all the attention and this happens if the combination has been chosen correctly. (The exception is of course for potters — they 'look through different eyes'.)

A potter may be approached to make some special containers for a Bonsai enthusiast (the term can cover anyone from raw beginner to skilled master) as those individually made rather than mass produced are much prized. Sometimes the markings of a handmade pot can assist identification in the event of loss or theft.

Pot collecting can be a hobby, especially of the miniatures and in Japan pot viewing is a leisurely pastime where collectors show their acquisitions to fellow enthusiasts.

Beautifully stored in fine cabinets, often wrapped in silk or fine paper signed by the potter, these pots are used for special showings when the tree will be potted up from a training pot of the same size just prior to an

exhibition, while afterwards the reverse takes place. Many of these fine old pots are extremely valuable — still others are never used, just viewed. The valuable trees are well cared for and don't suffer at all in the handling.

Many traditions and guidelines apply to Bonsai (there is even a viewing etiquette!) so the following points may assist you if you are to make any containers. Remember however, to offer a choice — the tree will be matched up to a pot, not vice versa.

Sizes range from *Dwarf* (palm of the hand) size under 150mm to *Small*, 450mm; *Medium to Large*, up to 1.5m; right up to *Two Man, Three Man, Four*

allow a tree-stabilising wire to be passed through.

A general rule of thumb states that the depth of the container should equal the width of the trunk of the tree to be planted in it. The average container would then be about 40mm deep. The most common shapes are oval and oblong (130 x 200mm or 150 x 200mm) but round and square are also used with variations such as 6 or 8 sided. They may have an overhanging rim or flush sides, the body may be straight-sided or gently curved under towards the base. Inward curves are not recommended.

Feet also have classifications,



*Man* — however many men are needed to carry it!

Bonsai are outdoor plants which only go inside for very short visits of say two days, and do not require saucers. Good drainage is essential so the pots will either be set up on feet or have obscure bases raised in the construction, so as to allow air circulation and excess water to drain away. At least one good sized drainage hole, say 10 to 20 cents piece size, must be provided though larger pots require two or even three — certainly more than the average gardener would estimate. In very shallow trays, 4 or more small holes are also needed to

*Cloud, Spot, Lion's Head* and so on, but your eye should guide you here; a delicate pot should be finished with fine feet while a plain sturdy one needs plain sturdy additions. Whether 3 or 4 feet they must be evenly spaced as the pot will be shown with either one foot facing the front, or halfway between 2 feet.

Natural unglazed pots are always 'right', though they are often the hardest to obtain and they should be well finished, not heavy or clumsy. Burnishing looks good with its warm clay tones. Conifers and evergreens are traditionally potted in unglazed containers, where the colour of the



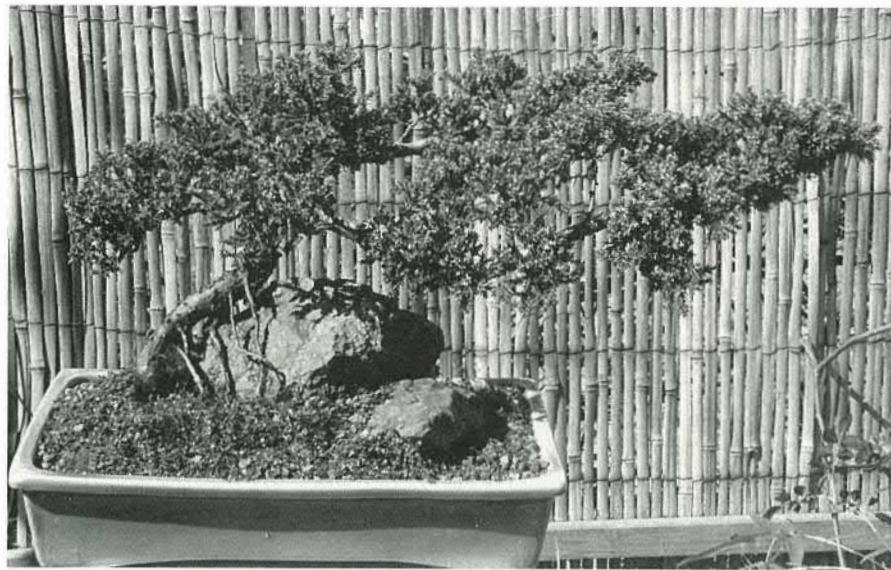

clay tones in with the bark. These rugged trees are referred to as 'masculine' with their sturdy appearance of trunk and foliage, so a plain, rather severe pot with solid feet suits them well.

Glazed pots are used for the flowering and fruiting plants and those with autumn limited foliage. These are classified as 'feminine', so the pots may have softer lines, neat feet and a complimentary glaze colour. White, cream, grey through to mirror black,

soft blue, aqua and green to dark cobalt blue. They are rarely decorated — remember the plant must be the eye-catcher — except perhaps for some raised, or incised lines which could pool the glaze and so define the shape. Leave the inside unglazed with just a 10 to 12mm return over the rim perhaps. If a plant has white blossoms, a deep blue might be chosen; orange berries or red leafed maples would suit a green or cream glaze; dainty pink flowers look delicate in a soft blue pot.

If the inside of the pot is still slightly porous, so much the better, rather than a highly vitrified clay, so a mid-range firing would be sufficient. Slab construction and moulds are possibly the most useful methods, or thrown and altered forms.

Cascading plants require a deep pot, round or square, but never oblong or oval. They can be 230 to 250mm high and 130 to 150mm across the top, tapering a little towards the base and either unglazed, or in a fairly subdued glaze. The greater area of pot visible in these examples would look too obvious if brightly coloured.

There is also a type of very shallow tray used for displaying rock-clinging plants grown in water or fine gravel. These pots will have no holes in the base and should also be glazed on the inside. The walls are only about 25mm high and the oval or oblong tray about 300 to 400mm long. Usually blues or greens are chosen to enhance the water, though plain dark brown clay would also be correct.

The right pot for Bonsai is the one which gives the most pleasing result — a total concept.

The Japanese  
Grow tiny trees  
About so high!  
I wonder why/  
Reginard Arke ■

**For perfect firing consistency.**

**ARCADIA DEVELOPMENTS LTD**  
43A LINWOOD AVENUE, MT ALBERT, AUCKLAND.  
P.O. BOX 87-088, MEADOWBANK, AUCKLAND 5,  
NEW ZEALAND. PHONE (09) 815 0815.  
Gas Fired and Electric Kilns.

### CRAFTS COUNCIL OF NZ

Our very own potter **Peter Gibbs** from Brightwater, Nelson, has been appointed editor for the *NZ CRAFTS* magazine, as well as the *NZSP* newsletter. You can also read what he has to say about crafts in the *NZ LISTENER*. There is no truth in the rumour that Peter's typing skills are outrunning those on his wheel — he still finds time to throw pots as well as use his wordprocessor. We wish him well in this new venture — and his magazine can be subscribed to from:

**Crafts Council of NZ**  
PO Box 498  
Wellington

### FOR SALE

ART GALLERY. New Zealand pottery and paintings, excellent location and position. Great business and lifestyle for artistic couple or person. **Phone (09) 412-9669 or (09) 412-7220.**

### SITUATIONS VACANT

The services of a hand thrower preferably with repetition production pottery skills is sought. The person should be a consistent thrower, have experience with stoneware and terra cotta bodies, self motivated, have finishing and decorating skills and be able to use an electric wheel. Expressions of interest together with relevant personal information and a portfolio of recent work (returnable) should be forwarded to: **Tom Devlin, Temuka Pottery, PO Box 5, Temuka, South Canterbury. Telephone: (03) 615-9551.**

# STARTING FROM COLD

Elizabeth F. Woodfield, Hamilton

Starting a down-draught kiln from cold still occasionally poses problems for the uninitiated, erstwhile kin builders and experimenters alike.

I was faced with this problem more than 21 years ago when in suburban Auckland, neighbours complained of nappies coming off their clotheslines dirtier than they went on. Although grey and pink is a pleasant combination, they simply did not like wrapping up their new babies in grey nappies!

After two workshop relocations and a natural draught kiln fired under cover of darkness (leaving a long trailing pall suspended over the river in the languid hours of early morn) I returned to the problem of cold starting with vapour jet burners.

The kiln was a typical stoneware, twin chamber, sprung arch, down-draught, diesel, brick kiln. Initially the four burner kiln was started with a pair of pot-burners each on opposite sides of the glost chamber. After two hours these were supported by the ignition of a second pair. All four revelled in billows of ominous smoke. Temperature in the front chamber was raised to 1000°C at which time fuel and blower were turned off to allow the changeover from pot-burners to vapour jet burners.

Amidst extreme nervousness (choking in clouds of fumes, smoke and tears, staccatoed with explosive popping as little bursts of fuel ignited) the redhot pot-burners were removed (hopefully without burning fingers or hair) to be replaced with the vapour jets. This also entailed changing fuel and air lines and moving the blower belt onto a different set of pulleys for increased air pressure and volume. Invariably there was a considerable drop in temperature and thus risk of pots exploding with the sudden ignition of the jets, to add to the terrors.

This rigmarole had to stop before I had a nervous breakdown. A way of firing without the terrible burner changeover midstream, had to be found — firing with one type of burner had to be easier, and cleaner!

Pot-burners would not carry the kiln to top stoneware temperatures. Vapour jet burners do not vaporise diesel until at a critical heat, but would go to extreme heat. Thus the search for cold start with vapour jet burners began.

I was not the only one trying to solve this dilemma. Experiments and progress were shared amongst myself, **Roger Britain** who was in Auckland and **Kevin Gaskill**, before he left Hamilton for life by the sea in Raglan.

The days of frustration and terror were soon supplanted by a slick method of fooling the vapour jet burners into

believing they really can start cold, earning the honour of firing full cycle from cold to 1300°C+.

This was achieved by rolling the vertical flame-throwing vapour jets onto their sides, in their ports. A wick was then inserted between each jet orifice and the side of its port, setting all so a gentle spray of fuel played onto the brickwork slightly above each wick. The original wicks were kerosene soaked rag rolled up in newspaper. Air behind the diesel started at 1/8" to 1/4" (yes, Imperial) water-pressure. The brickwork and wick thus simulated solid fuel and by the time the wick burnt away, the brick took over the job of maintaining the flame.

In this manner heat built up according to the quantity of diesel and air/water-pressure lifting the diesel. Firing was started with two burners, one each side of the chamber for the first two hours, after which time the second set were put in, also on their sides, partners facing.

As firing progressed, the vapour jets were systematically brought to the vertical position, usually when a voluminous amount of flame was at the top of the combustion chamber and half way down amongst the pots. I allowed four and a half to five hours to arrive at this point, about 1000°C, of my nine to 12 hour firings. Having balanced the four vapour jet burners I was then on the home run to 1300°C.

Air/water-pressure never went above two inches, otherwise the flame could have been blown cooler. At the conclusion of firings all burners were always removed from the kiln as a safety precaution.

In more recent years cold starting became even easier with the invention of *Lucifer* fire starters which replaced our wicks and although fire still triggers a nervous state, it also heralds excitement, many memories of friendships and *Shiva's* trident on other kilns far away.

It was interesting to note, when *Seeger* cones were no longer available, that the *Orton* cone 12 had to bend to a three o'clock position for the same maturity/temperature achieved by *Seeger* cone 9, which I had been using for years and understood to fall between 1280°C and 1300°C. Without the *Orton* 12 going half down, the same clay and glazes are not mature. I had fired my last *Seeger* 9 alongside a battery of *Ortons* to assess the necessary cone for the same temperature.

However, my primary guide for maturity of firing, is still of course, draw rings, made from the same pottery clay and glazed with the same glaze as the pots in that firing. It's always exciting, pulling those rings out of their fiery den at the height of the inferno. ■

### Air Pressure Gauge:

This gauge is to monitor the amount of air being fed through the burner system, in order to balance the air/fuel ratio during firing.

Air pressure is measured by the rise and fall of water pushed by the air flow in the burner.

Bend 3/8" of 3/8" plastic tube into a U shape 9" high and 5" wide, and clip it onto a backing board.

Attach a spirit level glass at the top of the board, as the whole gauge must be kept level during operation.

Mark out "0" level 3" up from the bottom of the U and 1/4" graduations above and below that line as illustrated.

Water is poured into the plastic tube up to the "0" level. When this tube is connected to the burner, via gauge line, D, the blown air pushes the water, altering its levels. The difference between the two levels is the water pressure, in inches. Example: falling 1/2" on right, rising 1/2" on left gives a reading of 1" water pressure. ■

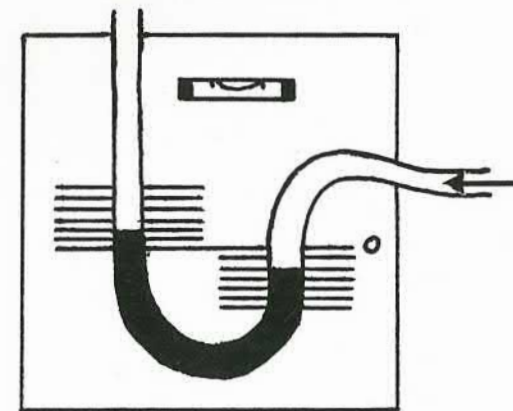



# DIESEL VAPOUR JET BURNER FOR 1300°C

## Materials:

- A. 28" of 2" galvanised water pipe for burner body.
- B. End plate for A.
- C. 34" of 3/8" type 316 stainless steel tube (heat corrosion resistant) for fuel line.
- D. 9" of 3/8" copper tube for air pressure gauge line.

## Burner Body, A:

Drill two holes approximately 2" from one end for C and D.  
 Drill, cut and file slot for fuel orifice — EITHER in upper surface of pipe, 1/2" from other end, for vertical flame — OR in end plate B for horizontal flame.

## Horizontal flame thrower:

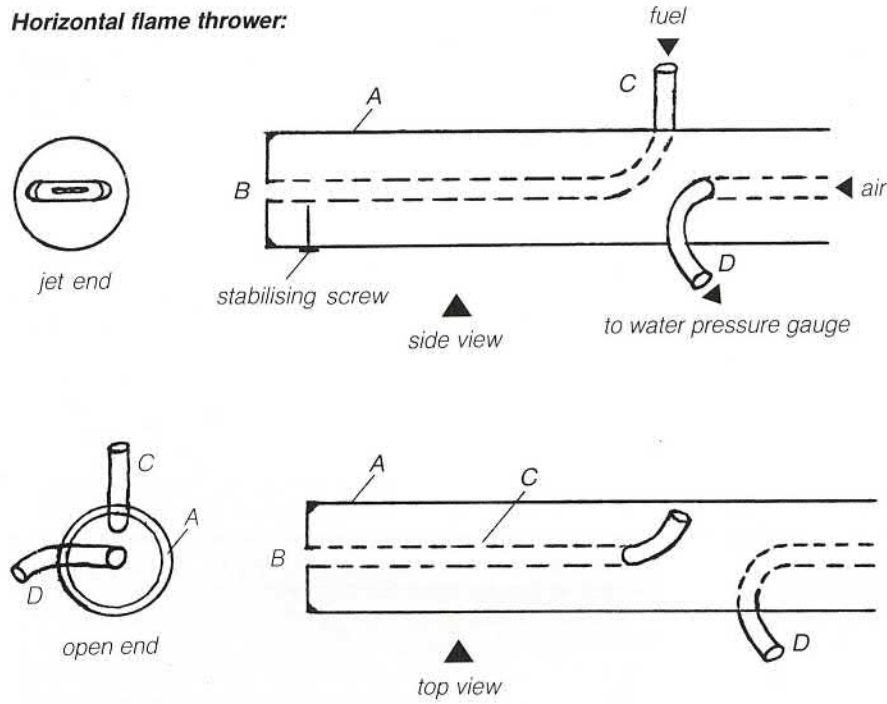

## Vertical flame thrower:

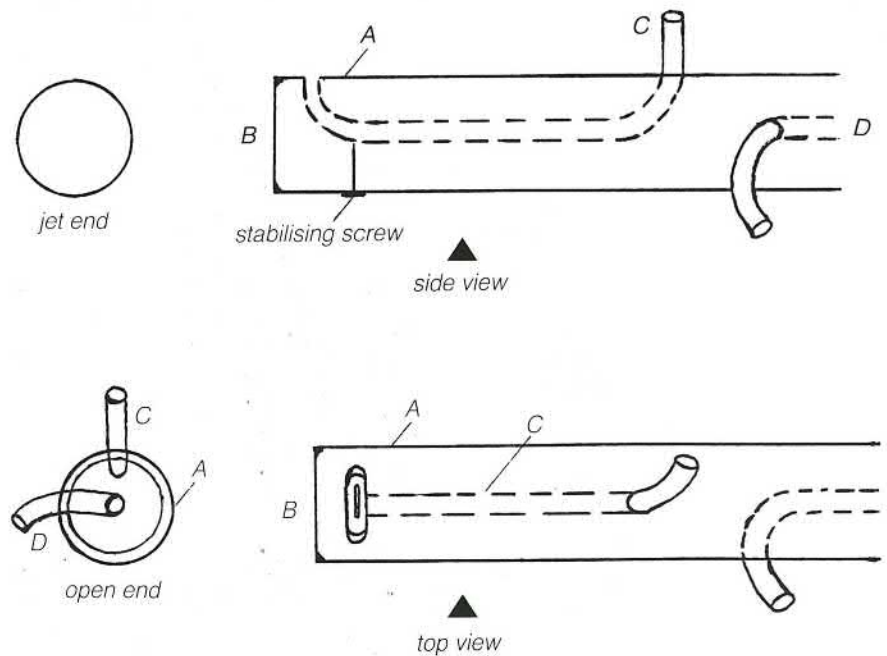

## End Plate, B:

For horizontal flame; drill 2 x 3/8" holes, the centres of which are 1/2" apart

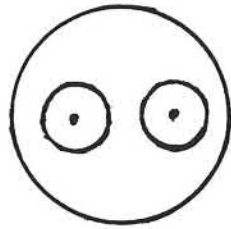

Cut along top and bottom of waist between holes to form one slot

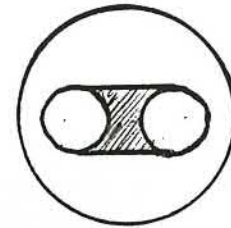

File ends of slot outwards

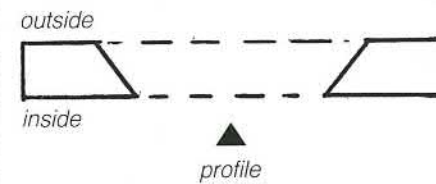
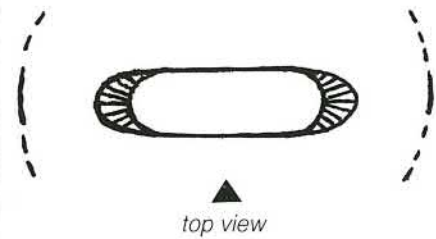

## Fuel Line, C:

Squash one end of tube to 21/1,000" — use a car feeler gauge — to form fuel orifice, and chamfer its edges with a file.

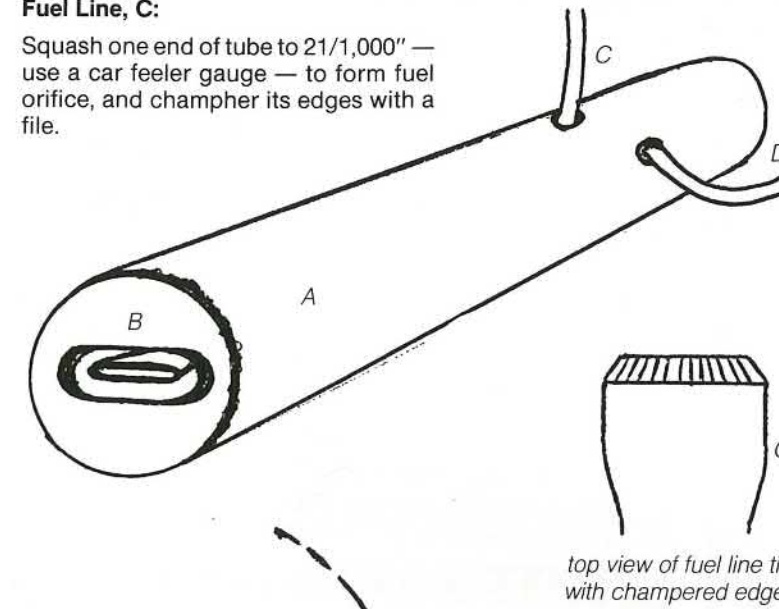

top view of fuel line tip, with chamfered edges

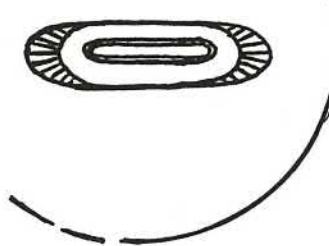

tip of orifice seen in slot of end plate

Bend fuel line, C, so approximately 6" will protrude from burner pipe, A. Weld or braze it in place so orifice of

fuel line, C, is a microsm inside edge of slot in end plate, B. Weld a screw under jet end to stabilise fuel line.

## Air Pressure Gauge Line, D:

Bend tube, D, so inlet end is flush with open end of burner pipe, A, and centred in the air flow. Weld into place. Finish your vapour jet burner by welding the end plate, B, in place.

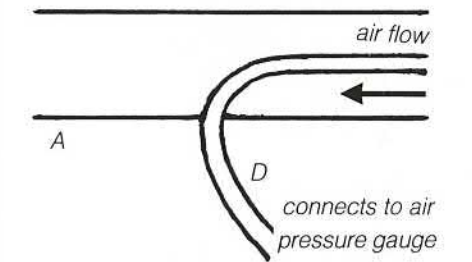

After approximately 150 firings, the end of the jet burner may need replacing. Simply cut the 4" or 5" of heat-corroded end off with a gas axe and fabricate a new one, welding it into place over the fuel line.

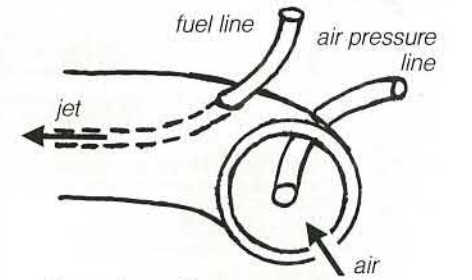

For awkward burner port positions, a right angled vapour jet burner is easily fabricated from an elbow section water pipe. This is ideal for reverberating raku kilns.

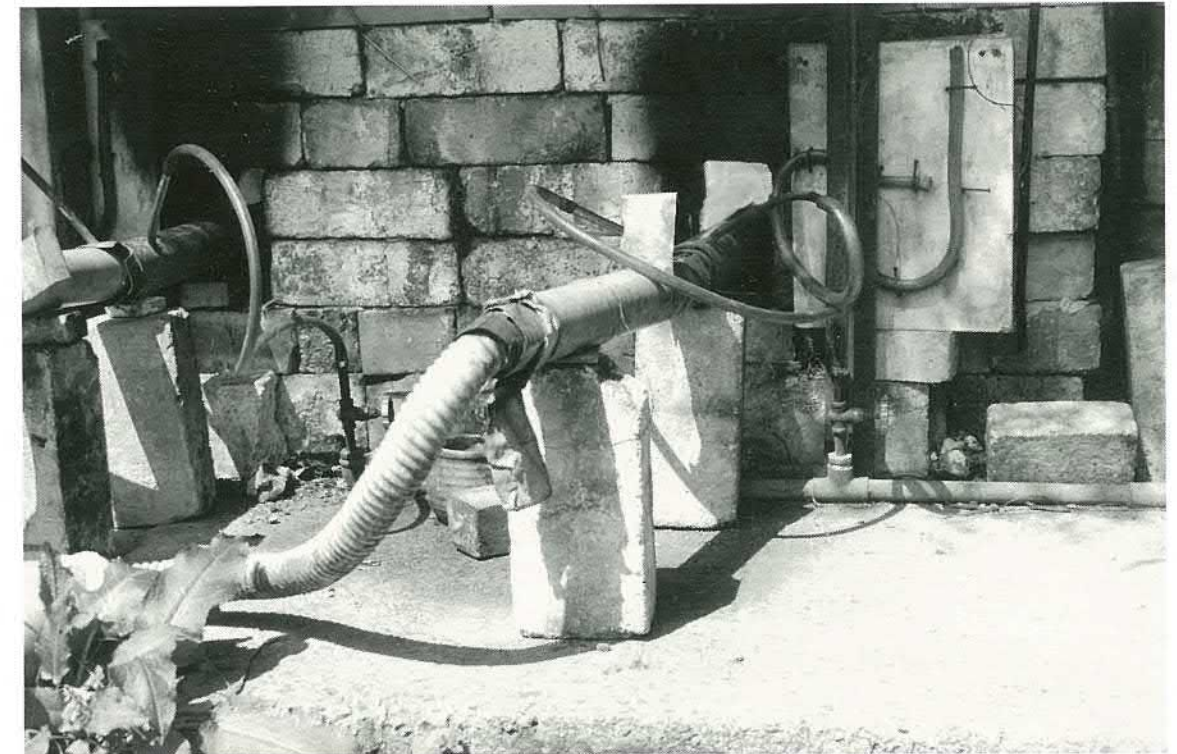



# GALLERY GUIDE

Entries for this listing cost \$15 — boxed \$20 — (incl GST) for up to 25 words. Cash with order, to NZ Potter, PO Box 881, Auckland. Next deadline 1st June.

## NORTHLAND

NORTHLAND SOCIETY OF ARTS — Reyburn House Gallery, Lower Quay Street, Whangarei. Monthly exhibitions of artists, craft people and various media — Hours: Tues-Fri 10.30-4.00, Weekends 1-4.

## NORTH AUCKLAND

PALMS GALLERY, Wayby, Pottery, wood, glass. Resident potters: Barry, Barbara, Scott and Arran Hockenhuil. Open 7 days (08463) 7125. Turn left 500m off S.H.1 15km north of Warkworth.

WARKWORTH CRAFT GALLERY CO-OPERATIVE Cnr Baxter and Neville St. Excellent selection of local pottery, woodwork, weaving, jewellery and clothing. Open 9.30-5.00 daily. Phone (09425) 8790.

## AUCKLAND

ALICAT GALLERY, 36 Jervois Road, Ponsonby, ph (09) 786-874. Open 6 days, fine selection of NZ pottery, paintings and custom framing.

ART AND SOUL, 434 Mt Eden Rd. Open 7 days. Pottery, glass, wood, knits, silk, jewellery, flax kits. Many craftspeople not represented elsewhere. Phone (09) 606-918.

ARTISAN CENTRE, Potters Co-operative, Broadway Plaza, Newmarket, Auckland. Ph (09) 524-0465. Decorative and domestic ceramics. Buy original work direct from 10 experienced potters. Open 6 days.

ATELIER GALLERY & STUDIO, The Esplanade, 1 Victoria Road, Devonport. Phone 451-190. Fine selection of NZ jewellery, silk, ceramics, and other fine quality crafts.

COMPENDIUM GALLERY, Victoria Road, Devonport. Ph (09) 451-577. Open 7 days/evenings. Greatest selection of quality NZ crafts anywhere — ceramics, jewellery, clothing, glass and woodware.

GALLERIE LA POSTE, former Takapuna North Post Office, corner Hurstmere Rd and Earnoch Ave. Excellent selection of top New Zealand artists, painting, pottery, mixed media and sculptures. Exhibitions change monthly. Phone (09) 461-702.

IAN FIRTH GALLERY, 15 Valkyria Place, Birkenhead. Fine art and sculptural ceramics in stoneware and terra-cotta. Individual commissions are a speciality. Phone (09) 434-285 Mon-Sat 10am-5pm.

KERAMOS ARTS CRAFTS, Henderson Square, Henderson. Phone (09) 838-6174. Pottery, wool hangings, cane, pure silk scarves, jewellery, sheep skin slippers from leading crafts people.

LOPDELL HOUSE, Waitakere Arts and Cultural Centre, three galleries, two craft working studios, craft shop. Open 7 days 10am-4.30pm. Phone (09) 817-8087.

MASTERWORKS GALLERY, Habitat Courtyard, 251 Parnell Road, Parnell. Phone (09) 395-843. Ceramics, glass, fibre, wood, jewellery. Superb selection of New Zealand's best. Open Mon. to Sat.

POTS OF PONSONBY, 298 Ponsonby Road, Auckland. Ph (09) 760-145. Craft co-operative gallery offering a wide range of quality handmade domestic and decorative pottery and other crafts.

SUNPARK GALLERY, Main Road, RD 2 Albany. 8kms north of Albany village. Excellent selection of fine pottery and ceramics. Open 7 days. Phone (09) 415-9373.

TEXTURES CRAFT GALLERY, 10 The Promenade, Takapuna. Phone 460-877. Selection of fine NZ craft concentrating on fibre, wearable art and flax. Exhibition space available to potters. Open 7 days.

THE BLUE STUDIO, 434 New North Road, Kingsland. Home of the Out of the Blue original, modern, bright ceramics by Brendan Adams. Ph (09) 896-376.

THE POTTERS GALLERY, 209 Hinemoa Street, Birkenhead. Phone (09) 418-1263. Fine range of porcelain, domestic and decorative pottery, silk scarves and kauri woodware. All by leading crafts people. Open 6 days.

THE RICH EARTH, Auckland's Crafty Place to shop, 106 Picton Street, Howick. Pottery, hand crafted kauri, lead lights, china painting, leatherware and knitted garments. Phone (09) 534-2321.

## WAIKATO

CADEAU STUDIO, 115 Alexandra Street, Hamilton. Domestic and Decorative pottery, weaving, handspun and mohair knitwear, bone carving, woodware, Wayne Sinclair's paintings and silk. Made by well known New Zealand crafts people. Phone (071) 389-096.

EXPRESSIONS — The Museum Shop, Waikato Museum of Art and History, Hamilton. The finest New Zealand pottery, glass, jewellery, silk, books, prints, cards. Phone (071) 395-100.

FIRE & FORM, Chartwell Square, Hamilton. Eleven potters and one woodcarver. Wide range of domesticware and decorative pieces. Monthly exhibitions by NZ craftspeople in various media. Phone (07) 556-638.

## COROMANDEL

ALAN RHODES POTTERY, Situated at Whenuakite, 23km south of Whitianga. Stoneware and pit fired pots. Studio attached to the gallery, visitors always welcome.

EASTERLY, Ocean Beach Road, Tairua. Specialising in quality pottery and garden ware. The shop and garden open to the public from dawn till dusk, daily.

MINISTRY OF WORX, Craft Gallery, Waikino. Haven of crafts including jewellery, wood-turning, soaps, perfumes. Specialising in stained glass and pottery. John and Trish MacReady. Ph (07) 863-7720. Closed Saturdays.

PENINSULA GALLERY, Showcasing the Peninsula's finest arts and crafts. Pottery, flowers and carved kauri. Monday-Saturday, 9am-5pm. Albert Street, Whitianga. Ph (0843) 65-224.

## WHAKATANE

THE RED BARN, State Highway 2, Whakatane. 7 minutes from Whakatane Post Office. Featuring locally made pottery and wide range of other crafts. Open 7 days.

## MANAWATU

SANSON POTTERY AND GALLERY, Main Highway, Sanson. Producers of individual handcrafted domestic and decorative pottery. Carmen & John Hackshaw. Open 7 days. Ph (063-293) 517.

## WELLINGTON

CAPRICORN GALLERY, 155 Jackson St, Petone. Handblown glass and studio pottery from leading NZ Potters, silk scarves, jewellery. Open 6 days to 1pm Saturday.

CLAYPOTS by Murray Clayton. Gallery and studio open the first weekend of every month or by appointment. Wide range of glazed pots. Takarau Gorge Road, Ohariu Valley. Phone (04) 784-080.

CLAYSHAPES GALLERY, 236 Oriental Parade, Wellington. A wide selection of fine NZ crafts. Pottery, woodturning, silk scarves, jewellery, bone carving, hot glass. Open 7 days, 10am-6pm.

HYDE PARK CORNER, Te Horo. Craft Village, Museum, Garden Centre and Coffee Lounge. Sells pottery, windchimes, garden ornaments, fountains, sculptures. Holds exhibitions occasionally. Open Tuesday-Sunday, 10am-4.30pm.

KIMBERLEY'S — Craft Gallery & Supplies. New Zealand Handcrafts Specialist. Kim Pemberton, Shop 3, Silverstream Village, Wellington. Ph (04) 287-065.

MALCOLM WARR STUDIO GALLERY, 26 Parata Street, Waikanae. Ceramic Sculpture by Maree Lawrence and original prints by Malcolm Warr. Open Monday-Saturday 9am-5pm. Telephone (058) 35-060.

MIREK SMISEK AND PAMELLA ANNSOUTH POTTERY, Main Highway, Te Horo. Open every day. Wide range of domestic, decorative and sculptural pieces in stoneware and saltglaze.

PAEKAKARIKI POTTERY, Pots by Neil Gardner — from fine glazed planters to vases and domestic ware. Visitors welcome, 65 Wellington Rd, Paekakariki. Phone (058) 28-396.

PAUL MESLER POTTERY, A wide range of domestic ware in six standard glazes. All pots handmade and woodfired. Norfolk Road to Mt Holdsworth, Wairarapa. Ph (059) 83-788.

REIKORANGI POTTERY and Riverside Animal Park, Ngatiawa Road, Waikanae. Jan and Wilf Wright invite you to experience a country environment. Open 7 days, 9.30am-5pm. Ph (058) 35-146 (Tea Rooms).

THE POTTERS SHOP, Kirkaldie and Stains Building, Johnston Street, Wellington. Phone (04) 738-803. A co-operative potters gallery offering their pots of excellence direct to the public.

## NELSON

SOUTH STREET GALLERY, Cnr Nile St West and South St. Here Nelson potters sell a wide variety of functional and imaginative work in historic surroundings. Exhibitions are shown in the upper Gallery.

WAIMEA POTTERY, When in Nelson visit Waimea Pottery at Craft Habitat, Richmond, to view a fine collection of lusted and domestic ware by Paul Laird.

## WEST COAST

COAST CRAFTS, 47 High St, Greymouth, West Coast. Ph A/H (027) 6102. Weaving studio and outlet for local pottery and crafts. Specialising in handwoven scenic wallhangings.

HOKITIKA CRAFT GALLERY CO-OPERATIVE, 25 Tancred Street, Hokitika. Multi-media gallery offering wide selection of quality craft works from top West Coast craftpersons. Open 7 days.

## CANTERBURY

ARTISANS GALLERY, 45 Rue Lavaud, Akaroa. Open daily 10am-5pm. Ph (03) 304-7514. New Zealand fine craft and craft art, studio pottery, ceramics, woodturning, weaving, furniture, jewellery, original casual clothing, silk, glass. Orders/commissions taken.

BARRHILL VILLAGE CRAFTS, Old School, Barhill, Sunday 2-5pm, for New Zealand woolcrafts, woodturning, pottery. Ph (03) 302-1720.

BARRHILL CRAFTS, McMillan St. Methven, Sunday-Friday 10.30am onwards.

COURTYARD POTTERY, 69 Rutland St, Christchurch. Ph (03) 355-5933. Specialising in quality pottery, glass and silks by New Zealand craft people. Open Mon-Thurs 9.30-5.30pm. Friday 9.30-8pm. Saturday 11-2pm.

CAVE ROCK & SALAMANDER GALLERIES, The Arts Centre Christchurch. For fine NZ crafts and works on paper. Phone (03) 365-1634.

EASTSIDE GALLERY, Specialising in quality pottery, woodwork, fabric craft, paintings, silk scarves, woollen garments, weaving. 724 East Street, Ashburton. Ph (053) 89-550. Open 7 days, 9.30am-5.30pm.

MAINLY POTS, 95 Main Rd, Redcliffs, Christchurch. A co-operative of local potters. Colourful domestic and decorative pots and crafts. Open every day. Enquiries: Lis (03) 844-1000.

SEVERAL ARTS, 807 Colombo Street, Christchurch. Phone (03) 669-264. Fine NZ art and crafts since 1960. Open Mon-Thurs 10am-5pm. Fri 10am-6pm. Sat 10am-1pm.

## MARLBOROUGH

MACMILLAN GALLERY (MHJ). Pottery, paintings, bronze sculpture, terracotta bird baths, feeders, etc. Commissions. Open Monday-Saturday, 10am-5pm. Cnr Inkerman Street, 5 West Coast Road, Renwick, Marlborough.

## SOUTH CANTERBURY

COUNTRY CRAFTS MAKIKIHI INC (1977). St Andrews Co-operating Parish, Makikihi. For quality pottery, woodcraft, woodwork, leather work. Open Monday-Saturday 10am-4.30pm or on request. Enquiries Noeline (0519) 25-708 or Pam (056) 24-731.

## OTAGO

DUNEDIN POTTERY, 201 Stuart Street, Carnegie Centre, Dunedin. Phone (03) 477-1163. Local pottery domestic and decorative teapots to dragons, woollen products, plus pottery supplies, tools, clay, glazes etc.

## FLETCHER CHALLENGE CERAMICS AWARD 1990 EXHIBITION

*If anyone is interested in purchasing photographic material that has been returned from various publications, please telephone the A.S.P. Centre 0-9-643 622 for details.*

Prices at cost: 35mm colour slides \$3 each  
6x7cm colour transparencies \$20 each  
20x25cm black and white prints \$20 each

## NORTH SHORE HIRE CARAVANS & TENTS

105 Wairau Road, Takapuna

Special Rates for POTTERS  
Ph. 444-8343  
478-6649

BP Gas  
The LPG Authority

MASTER FILLING AGENTS

John Anderson  
Mary Hardwick-Smith  
Barbara Hockenhuil  
Barry Hockenhuil  
Peter Lange  
Renton Murray  
Peter Oxborough  
Cecilia Parkinson  
Heather Skeates  
Robyn Stewart  
Peter Stichbury  
Margaret Symes  
Andrew van der Putten  
Howard Williams  
Marilyn Wiseman  
Ph. 415-9403  
Open 7 days 9 am-5.30 pm

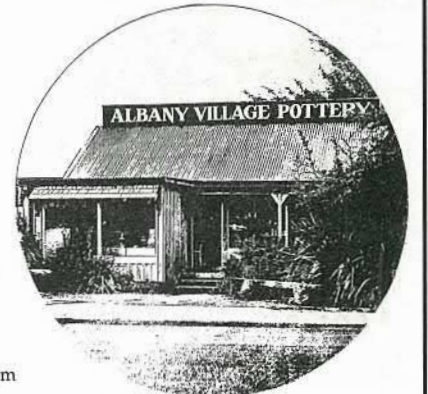

## The Old Dairy Factory Crafts

Pottery  
Crafts  
Sheepskins  
Souvenirs



Station Road, Waimauku Village  
25 minutes drive from Auckland.  
Opp. Muriwai turnoff.  
Ph: (09) 411-8665

OPEN 7 DAYS  
Mon-Thurs 10am to 5pm  
Fri-Sat-Sun 10am to 6pm

# FIRST KILN - REXMARK FIRST CHOICE

### FIRST IN LIGHTWEIGHT CONSTRUCTION

Two people can easily lift this kiln to move or transport in your car no expensive flue required - fire in the open then back into storage

### FIRST IN RIGID CERAMIC FIBRE LINING

The best ceramic fibre for a potter's kiln - better able to take the knocks and vacuum clean

### FIRST IN PERFORMANCE TO 1300°

No other burners match ours for speed and easy operation - half a cone evenness guaranteed

### FIRST INNOVATIVE PATENTED DESIGN

This is the first true downdraft kiln to convert to updraft operation for gentle biscuit firing - again we were first to design and make the modern zircon slip cast flue system. We are continually improving this design - our first is 1000 firings old and still going strong

### FIRST IN GAS KILN TRAINING

Only we give you professional training in all aspects of gas kiln firing - be confident in stacking, reduction or oxidation firing, safety, maintenance and even glaze analysis

### LAST IN EXPENSIVE KILNS

No other kiln of this size beats our price - 12 months warranty and excellent after sales service

6.0 cubic foot two burner - \$1820 incl. G.S.T.

3.6 cubic foot one burner - \$1485 incl. G.S.T.

Enquire further for information on our range of production kilns up to 60 cub ft

**REXMARK DEVELOPMENTS LTD** 58 Athens Road Onehunga, Auckland

Phone 643-311

"The gas kiln specialists - working exclusively with studio potters"



# SUNPARK GALLERY

STATE HIGHWAY 1, R.D.2, DAIRY FLAT, ALEANY, AUCKLAND. (09) 4199-373  
FINE POTTERY AND CERAMICS  
CECILIA PARKINSON JOHN PARKER

## Easterley The Cottage Craft Shop

Specialising in Garden Pottery

David & Pat Boyes

P.O. Box 20 — Phone 48-526  
Ocean Beach Road, Tairua, N.Z.

## Mouldcraft



Ceramic Design  
Original models  
blocks  
cases  
&  
mouldmaking

Bruce Yallop

work 878-650  
home (09) 817-7875

## WELLINGTON POTTERS SUPPLIES

All pottery requirements  
NZ and imported clay, low-cost porcelain

Agents: Cobcraft & FE kilns, Cowley wheels and  
equipment, Blythe stains.

Specialist element service: Replacement elements for all kilns.  
Also element upgrades for kilns with uneven heat, slow firing,  
or with short-life elements.

2 Cashmere Avenue, Khandallah,  
Wellington. Telephone (04) 791-211

## WESTLEY INSURANCES LTD.

Westley Insurance are a firm of Insurance Brokers who specialise in Insurance for small businesses and in the individual. We administer the New Zealand Society of Potters Insurance Scheme and would be happy to consider your business either as an individual or a group.

*We suggest you drop us a line and allow us to discuss the Benefits with you.*

P.O. Box 33-655, Takapuna, Auckland 9.  
Phone: Bus. 461-283. Pvte. 456-146. Fax. 498-011

## ROSS MELVILLE BRIDGMAN & Co.

CHARTERED ACCOUNTANTS

50 ANZAC AVENUE  
AUCKLAND

FAX (09) 393-247

P.O. BOX 881  
TELEPHONE (09) 798-665

INTERNATIONALLY PANNELL KERR FORSTER — ASSOCIATES THROUGHOUT NEW ZEALAND.

ARE PROUD TO BE SUPPORTING "NZ POTTER"  
& ASSOCIATED CRAFTSPEOPLE IN NEW ZEALAND

# Still NZ's Most Popular Wheel



Manufactured by

## TALISMAN

Manufacturing

Improved  
model  
now has  
1/2hp  
motor

124 Rimu Road, Paraparaumu, New Zealand  
Phone 058-84377 Fax 058-73107



# INTRODUCING **PC: RED**



ROSS RICHARDS THACKWOOD POTTERY WAKAPUAKA — NELSON

**A New Rich Red Earthenware Clay**

■  
**Firing to 1168°C — Cone 03 - Cone 3**

■  
**Oxidation & Reduction Atmosphere**

■  
**Coarser and Stronger (than E2)**

■  
**Suitable for Larger Pieces**

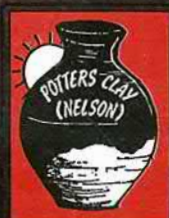

Available from Distributors throughout New Zealand  
For Further Information write:

**POTTERS CLAY (NELSON) LTD**

42 Quarantine Road, Stoke. P.O. Box 2096, Nelson.

Tel. (054) 73-397 or after hours (03) 547-3397 after June 1991